

# 4X4 BLAZING



# BLAZER

## 1/10 RADIO CONTROL 4WD SPORT PICK-UP TRUCK

©1982 By Tamiya Plastic Model Company. All rights reserved.

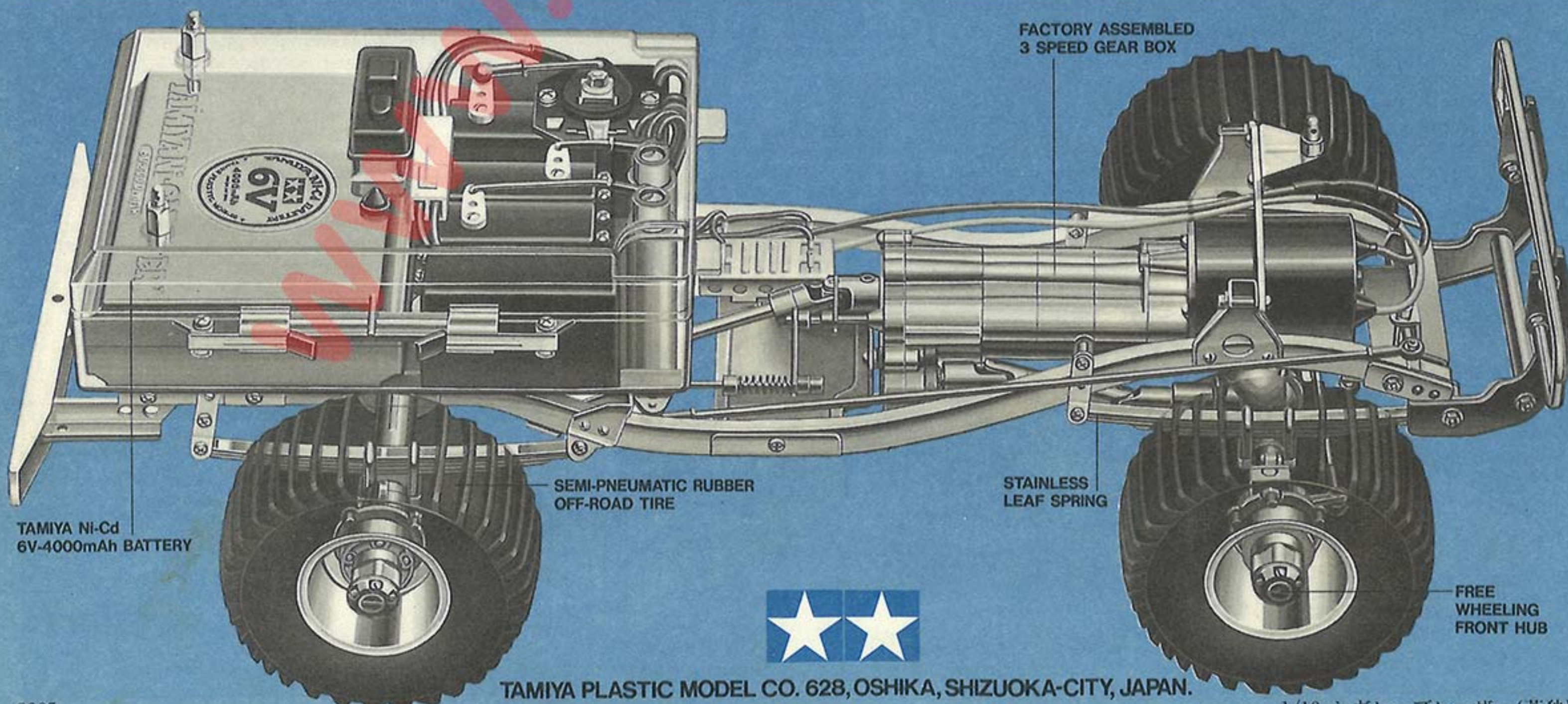

FACTORY ASSEMBLED  
3 SPEED GEAR BOX

TAMIYA Ni-Cd  
6V-4000mAh BATTERY

SEMI-PNEUMATIC RUBBER  
OFF-ROAD TIRE

STAINLESS  
LEAF SPRING

FREE  
WHEELING  
FRONT HUB



TAMIYA PLASTIC MODEL CO. 628, OSHIKA, SHIZUOKA-CITY, JAPAN.

# 4X4 BLAZING BLAZER



## «Assembly of 4x4 Blazing Blazer»

Tamiya's model was engineered to move forward/reverse, steer left/right and shift gears while in motion by aid of a digital proportional radio control unit. Be sure to have the following ready prior to beginning assembly.

## «Zusammenbau des Blazing Blazer»

Das Tamiya Modell fährt vor und rückwärts, links, rechts herum und wechselt die Fahrgeschwindigkeit durch den Einbau einer Digital-Prop. Funkfernsteuerungs Anlage. Vor Baubeginn sollte folgendes bereit liegen.

## «Radio Control Unit»

For optimum enjoyment and performance it is recommended that a four channel, three servo R/C unit be employed. A two channel, two servo radio can be used, but gear shifting will then be manual.

## «RC Anlage»

Es ist zweckmässig, eine 4 Kanal Anlage mit 3 Servos zu verwenden. Hat man nur eine 2 Kanal Anlage mit 2 Servos, muss die Geschwindigkeit mit der Hand eingestellt werden.

## «Power Source»

Separate power sources are utilized for R/C and driving motor. This kit was designed around the new Tamiya 6V-4000mAh Ni-Cd battery. It is possible to use the 6V or 7.2V 1200mAh batteries, however driving time will be reduced to approximately 6-8 minutes before depletion. The 4000mAh battery will provide up to 30 minutes of driving at full power before recharging is required. Being that Ni-Cd batteries are rechargeable, they are the most economical.



with exclusive connector set

Tamiya Ni-Cd 6V-4000mAh Battery (RB-0012)

## «Stormversorgung»

RC Anlage und Motor haben getrennte Stromquellen.

Verwendet sollte der neue Tamiya 6V-4000mAh NC Akku werden. Fahrleistung ca. 30 Minuten, wiederaufladbar. Es ist möglich, die 6V oder 7V Akku mit 1200mAh zu verwenden, die Fahrzeit ist jedoch höchstens 6~8, Minuten. NC Akku's sind aufladbar und daher lohnt sich die Anschaffung eines Ladegerätes.

## «Tools in this kit»

### «Werkzeug im Kasten»

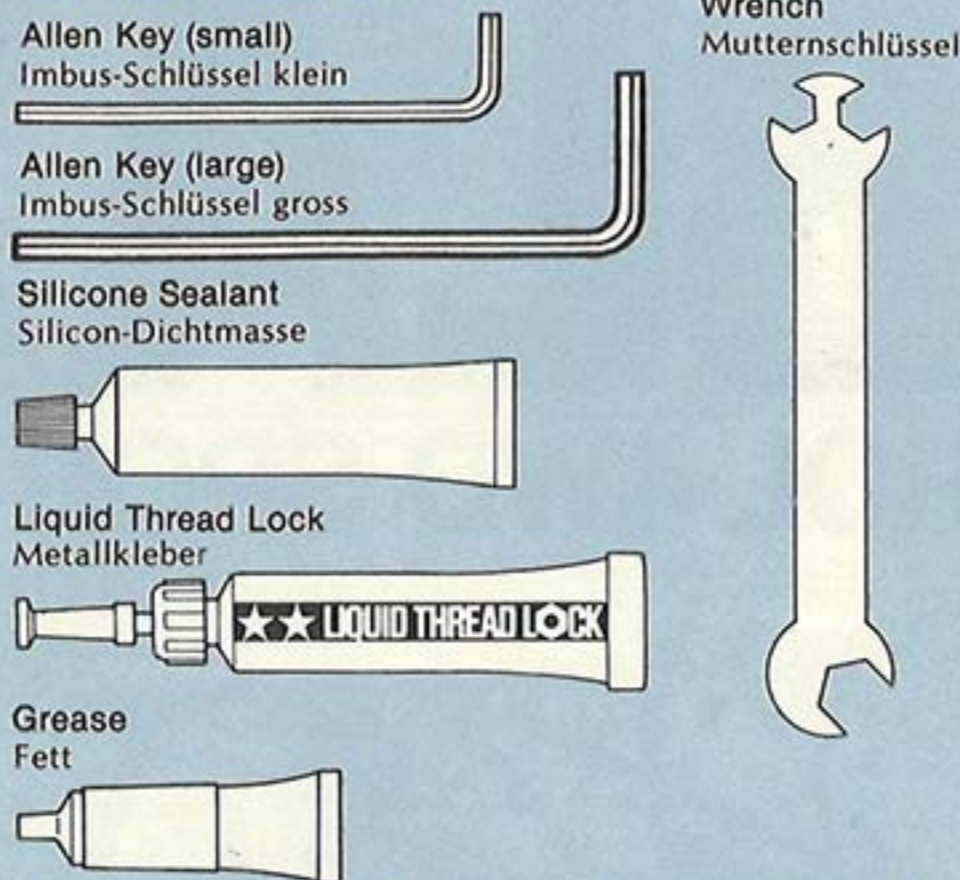

## «Additional Tools & Parts Required (not included in kit)»

### «Folgendes Werkzeug wird benötigt (im Kasten nicht enthalten)»

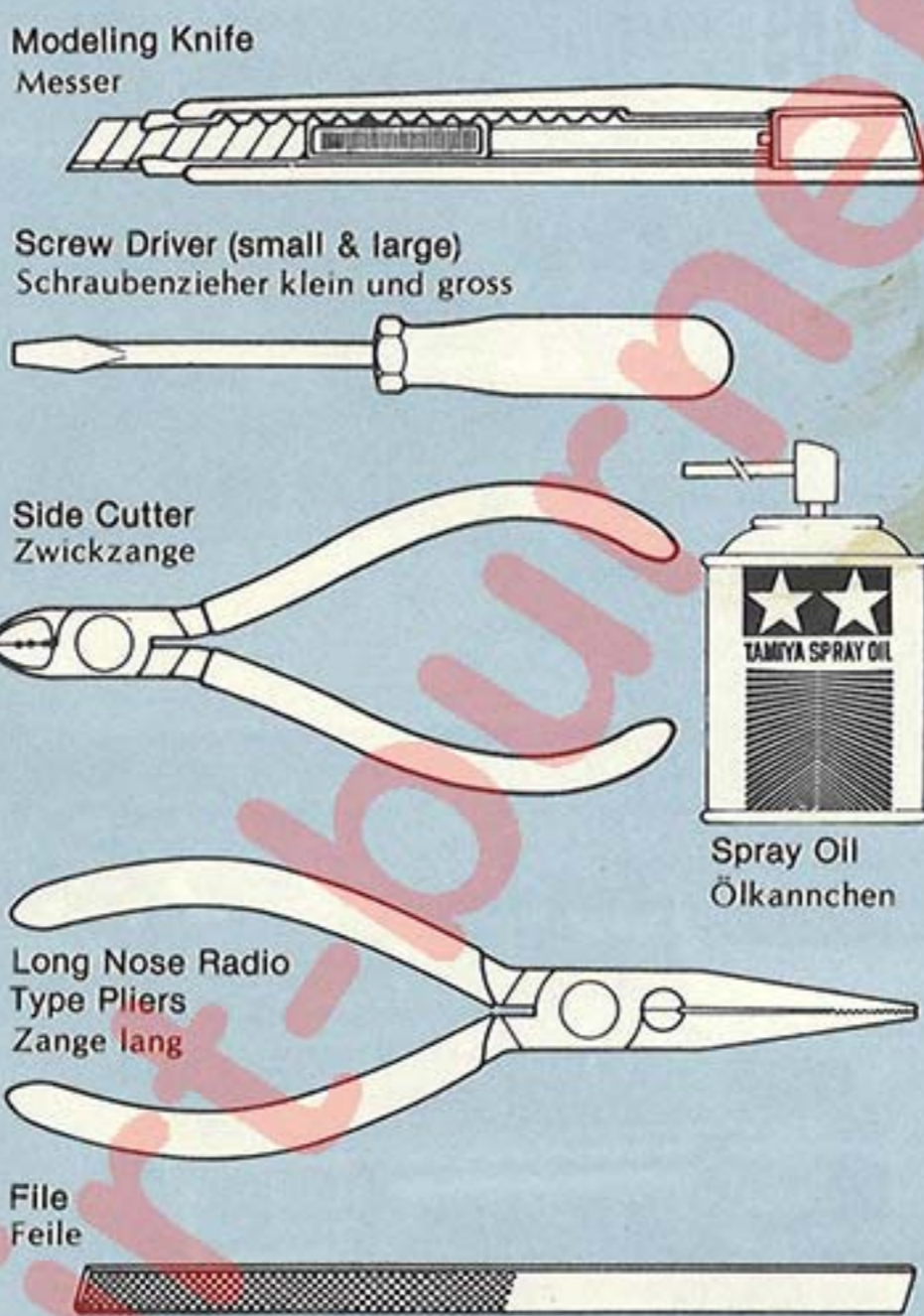

Tweezers and cellophane tape will also assist in construction.  
\*Pinzette und Tesafilm erleichtern das Bauen.

## Tamiya Spray Oil

This is a product of high polymer chemistry developed in the U.S.A. and is superb in avoiding moisture, cleaning surfaces and in lubricating running parts. An additional tube is provided to spray oil into hard to reach places. This is an indispensable spray for use with radio controlled model cars.

## Öl-Spray

Bewegliche Teile sollten mit Öl-Spray geschmiert werden.

## Tamiya Liquid Thread Lock

Tamiya Liquid thread lock is ideal for fixing nuts and bolts in position. Apply it either directly onto the screw thread or after tightening of the nut or bolt. Thereafter, you will be free of troubles like lost nuts and bolts when running your radio controlled cars.

## Metallkleber

Schrauben und Muttern, blau gezeigt in der Bauanleitung, sollten mit Metallkleber festgeklebt werden. Abgehen während des Einsatzes wird dadurch verhindert.

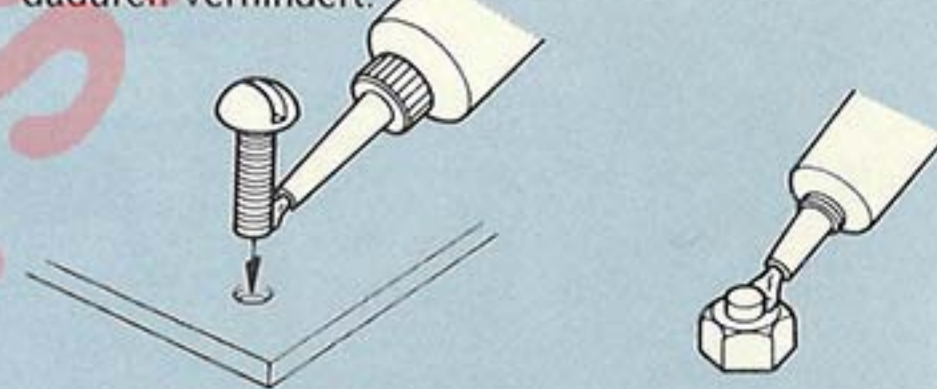

## «Blazing Blazer»

The Chevrolet Blazer pick up trucks have been very popular among the off road set for extensive modifications into racing and sport 4x4's. No two have been modified exactly alike; however, all seem to have the same general outward styling. A large roof wing, oversized wheels and tires; heavy duty roll cages for protection, plus bush guards and strong rear bumper. Painted up in flashy colours and lots of markings make these fun vehicles really stand out in a crowd. They are used weekends for leisure activities and week days for normal transportation and workload. The stock blazer is a fine performing rugged vehicle right from the sales room. Modified into a sports 4x4 it adds another dimension to an already highly engineered pick-up.

Der Chevrolet Blazer Pick-up ist sehr populär im Geländesport oder Rennen. Obwohl es scheint, dass diese Fahrzeuge von Aussen gleich aussehen, gibt es jedoch keine zwei gleichen Blazer. Beachtenswert ist der grosse Dachspoiler, die übergrossen Räder und Reifen, die schweren Überrollbügel, der Rammschutz und die starke, hintere Stosstange. Die flammenden Farben und die vielen Markensticker helfen dazu, dass das Fahrzeug überall auffällt. Werktags als Transportwagen im Einsatz, am Wochenende als Freizeitspass ist dieser Wagen mit Vierradantrieb eine andere Dimension des hervorragend gebauten Pick-up.

## «RC Equipment»

### «RC Anlage»

### ★ Check out RC equipment.

### ★ RC Anlage auf Vollständigkeit prüfen.

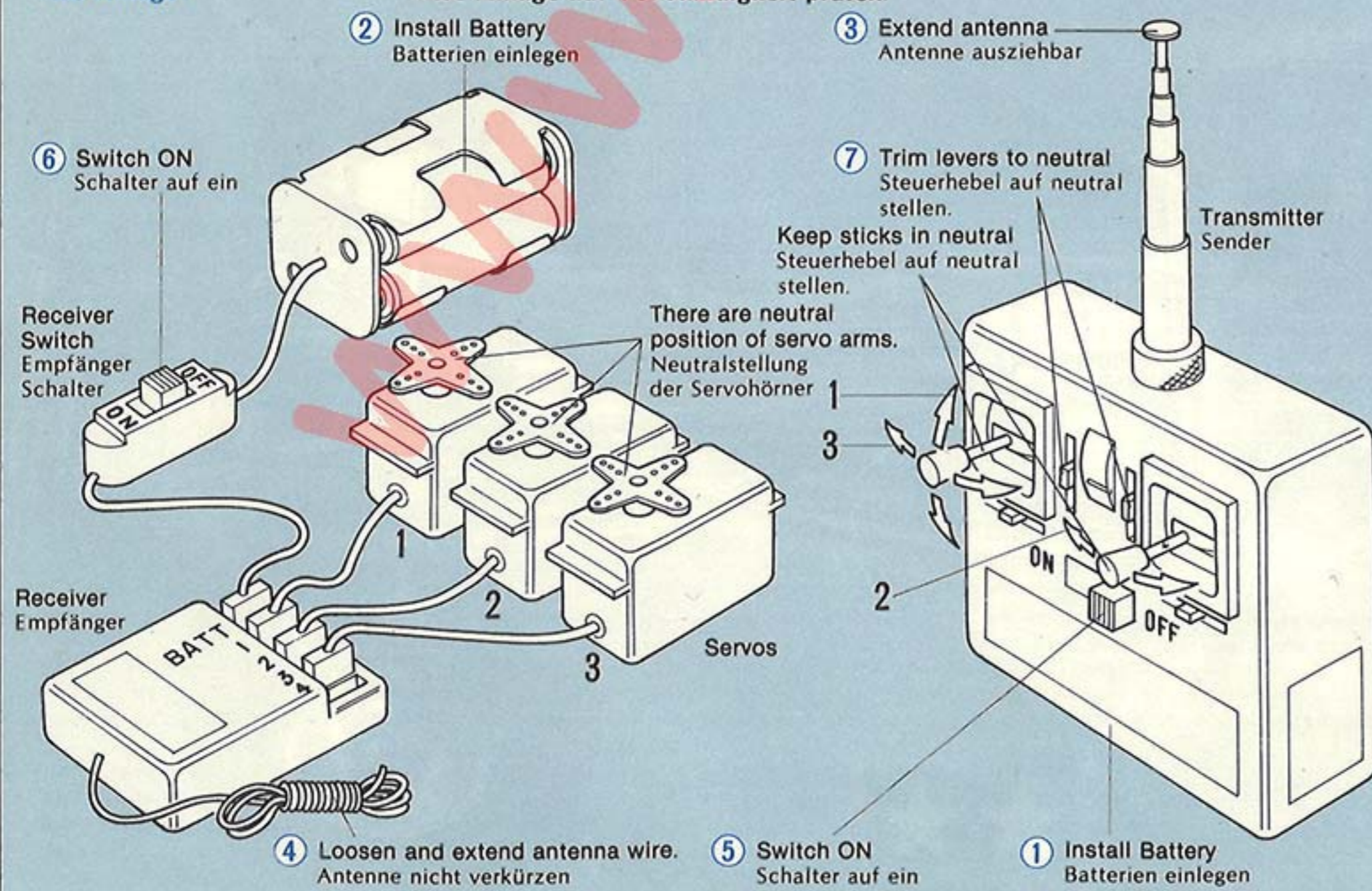

## «Composition of Digital Proportional System»

The digital proportional system comprises a transmitter, receiver, servos, etc.

**Transmitter** : Serves as a control box. Stick movements are transformed into radio wave signals which are transmitted through the antenna.

**Receiver** : Receives signal from the transmitter.

**Servos** : Servo transforms signals received by the receiver into mechanical movements and actuate the control portion of the car.

## «Funkfernsteueranlage»

**Sender** : Hebelbewegungen werden in Funkwellen umgesetzt und geben über einen Empfänger Impulse an die im Auto eingebauten Servos.

**Empfänger** : Empfängt Signale vom Sender.

**Servos** : Signale vom Empfänger werden im Servo mechanisch übersetzt.



★ Properly identify all screws, washers, gears and bearings etc. and gather together those necessary for each step. Carefully read and study the drawings prior to assembly.

★ The most suitable driving power source for this kit is Tamiya Ni-Cd 6V-4000mAh battery. You can enjoy about 30 minutes continuous driving between charges. Tamiya Ni-Cd 6V-1200mAh and 7.2V-1200mAh batteries can also be utilized.

★ Paper header of each screw bag shows number of parts required for construction. Extra parts are included. Use them as spares.

★ Viele kleine Schrauben und Muttern etc. müssen genau der Anleitung nach eingebaut werden. Exaktes Bauen bringt ein gutes Modell mit bester Leistung.

★ Tamiya Akku 6V-4000mAh, Fahrdauer ca 30 Minuten.

★ Kopfleiste der Schraubenbeutel gibt die Anzahl der benötigten Schrauben an.

- Apply silicone sealant to protect from water or oil.
- Apply only enough cement to get a good bond.
- Grease/oil. Be sure to oil prior to assembly.
- Apply Tamiya Liquid Thread Lock (Metal Cement)
- Silicon-Dichtmasse
- Klebestellen Klebstoff auf beiden Seiten anbringen.
- Ölen oder fetten (grease)
- Metal-Kleber

**1** «Parts (full size)»  
«Teile in originalgrösse»

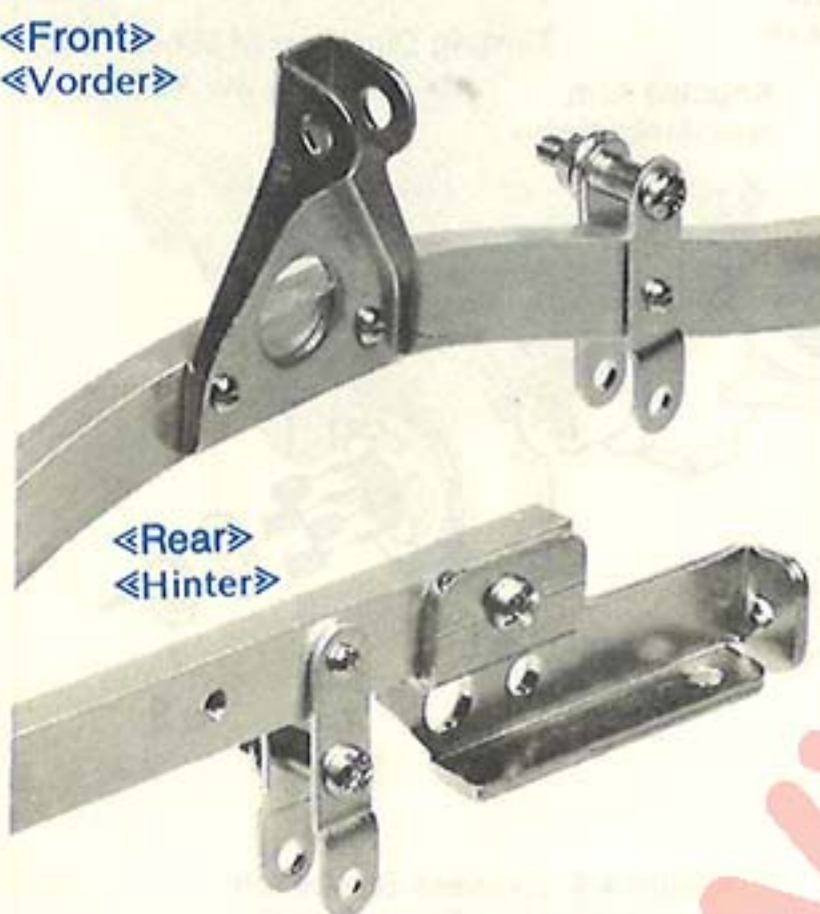
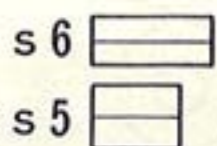

**2** «Parts (full size)»  
«Teil in Originalgrösse»

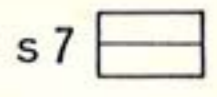

**1** Frame Assembly 1  
Rahmenbau 1

«Frame R»  
«Rahmen R»

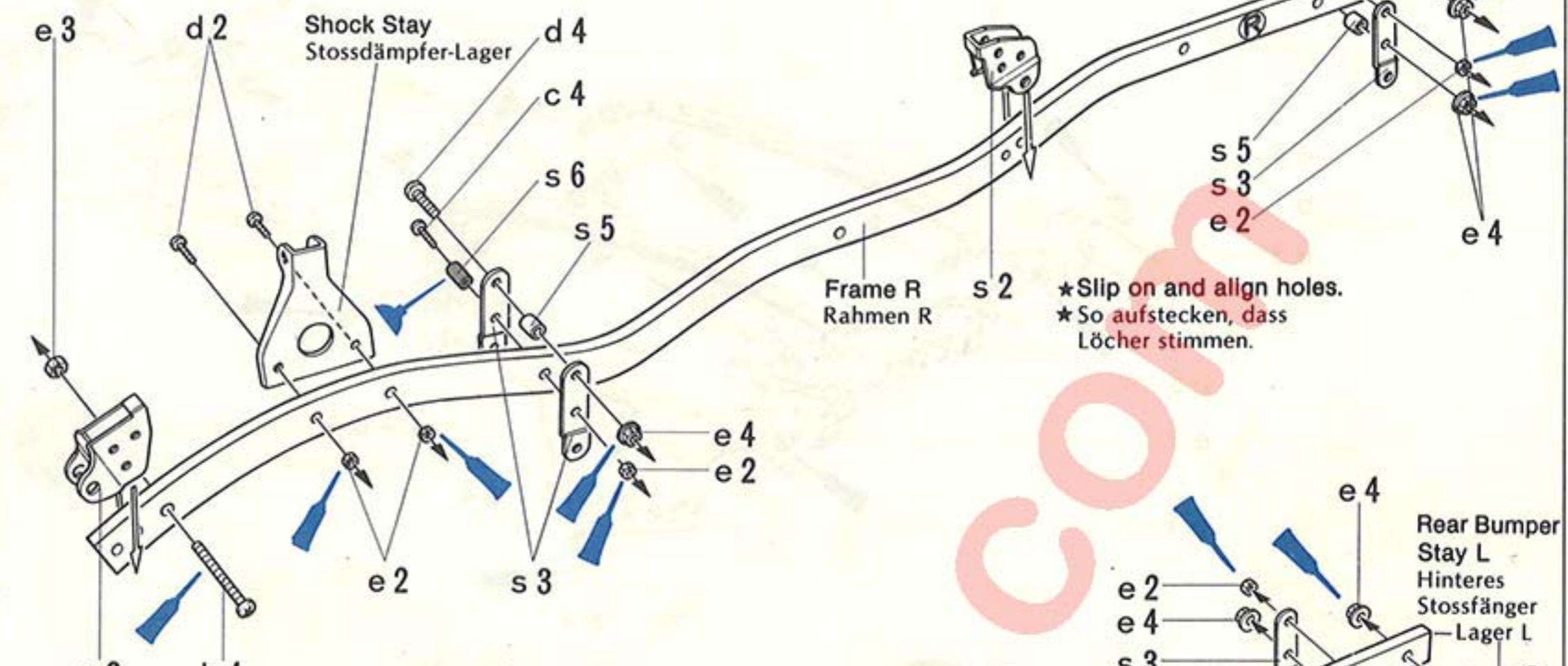

«Frame L»  
«Rahmen L»

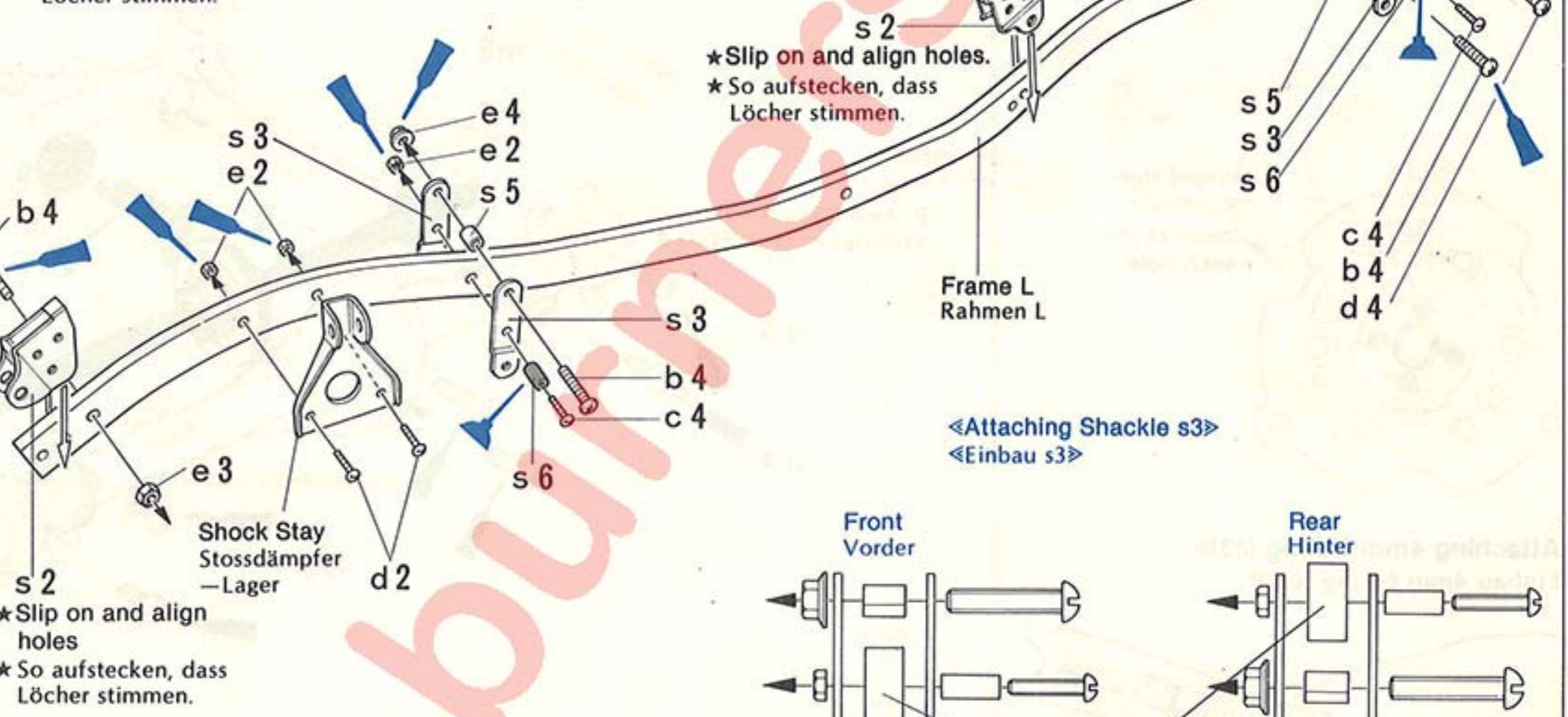

**2** Frame Assembly 2  
Rahmenbau 2

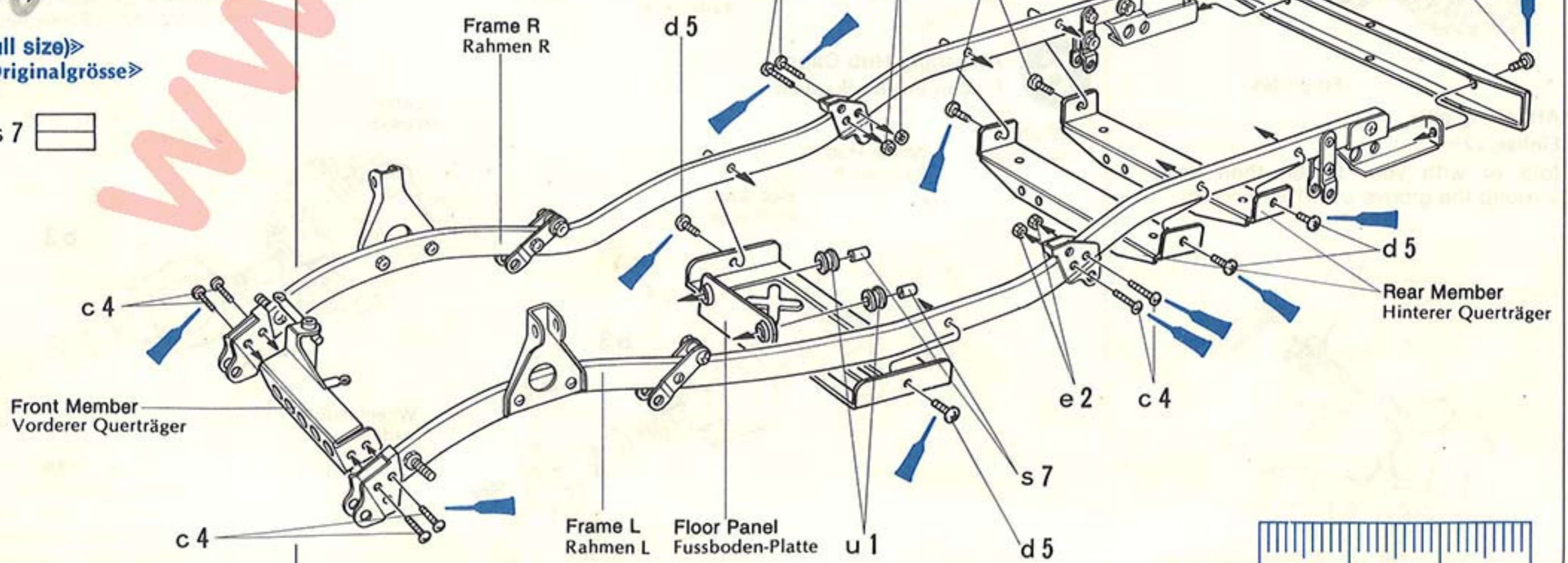
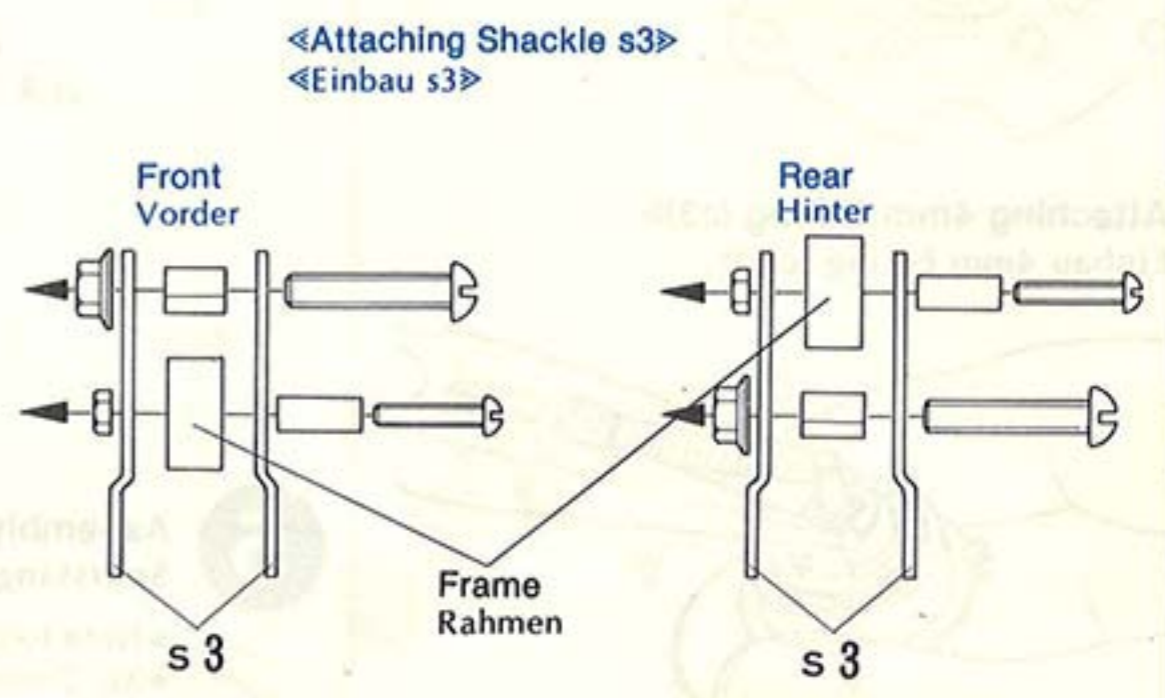
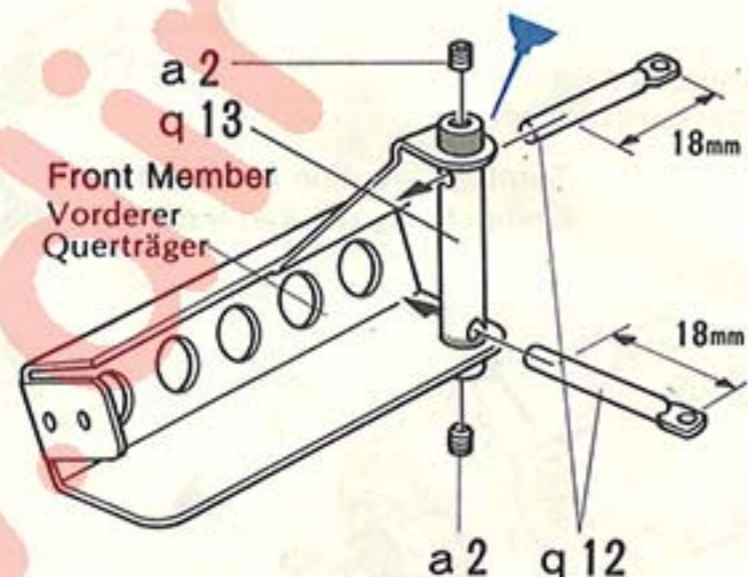

**3** «Attaching Leaf Springs»  
«Einbau der Blattfedern»

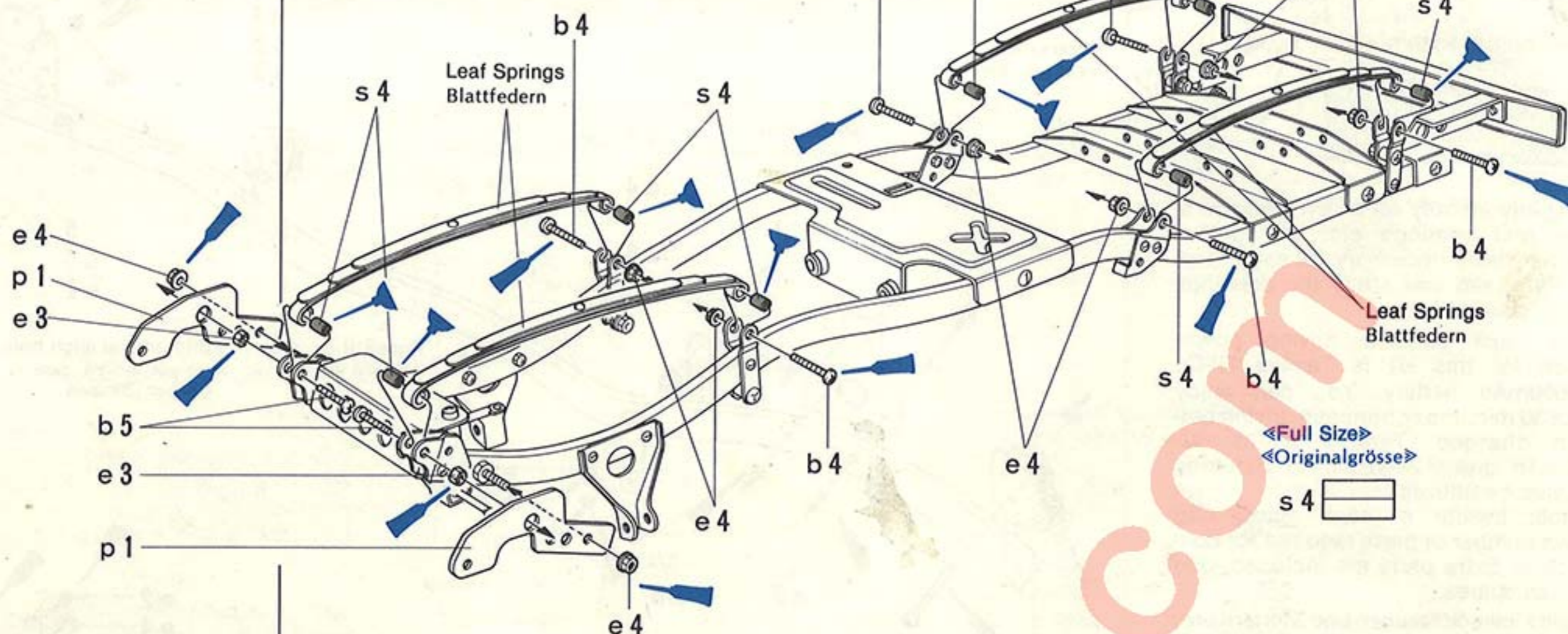

**5** «Inserting Stainless Pins (c1)»  
«Zusammenbau des Nadellagers»

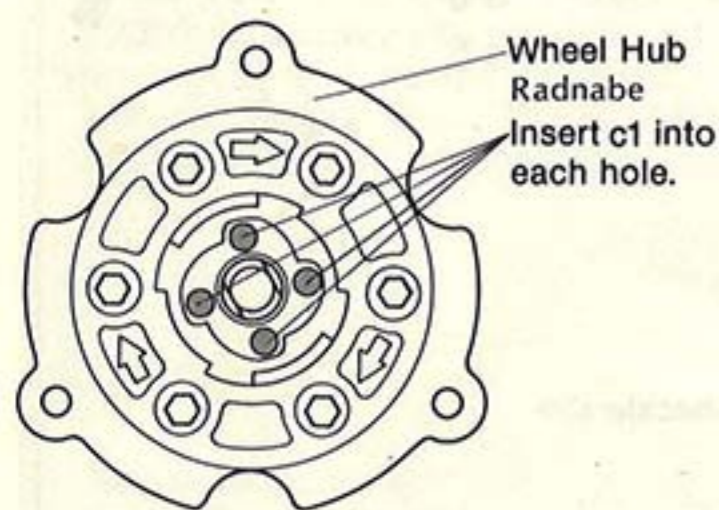

«Attaching 4mm E-Ring (c3)»  
«Einbau 4mm E-Ring (c3)»

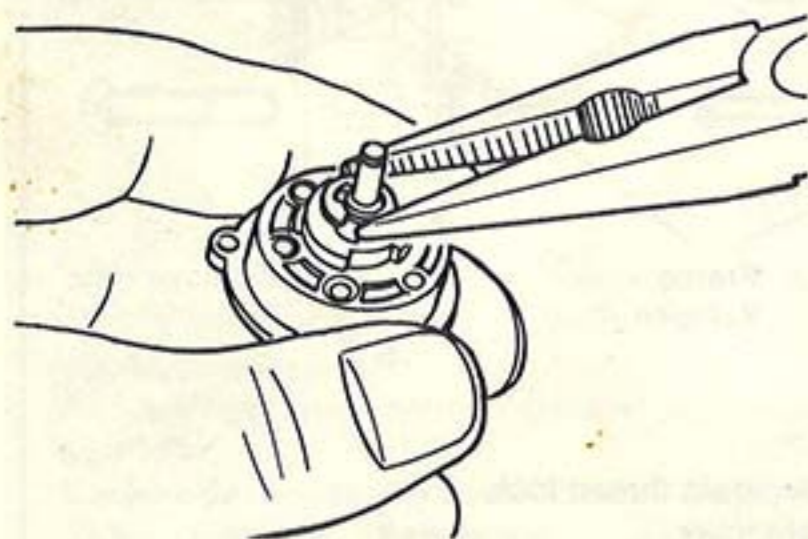

**6** «Attaching Hub Cap»  
«Einbau der Radkappe»

Fit into place while moving shaft.

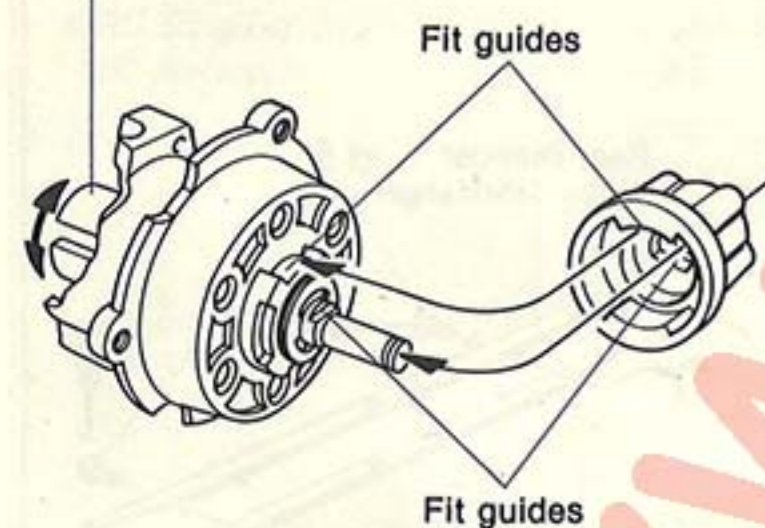

«Attaching c2»  
«Einbau c2»

Hold e1 with your finger, then snap c2 along the groove of m1 as shown.

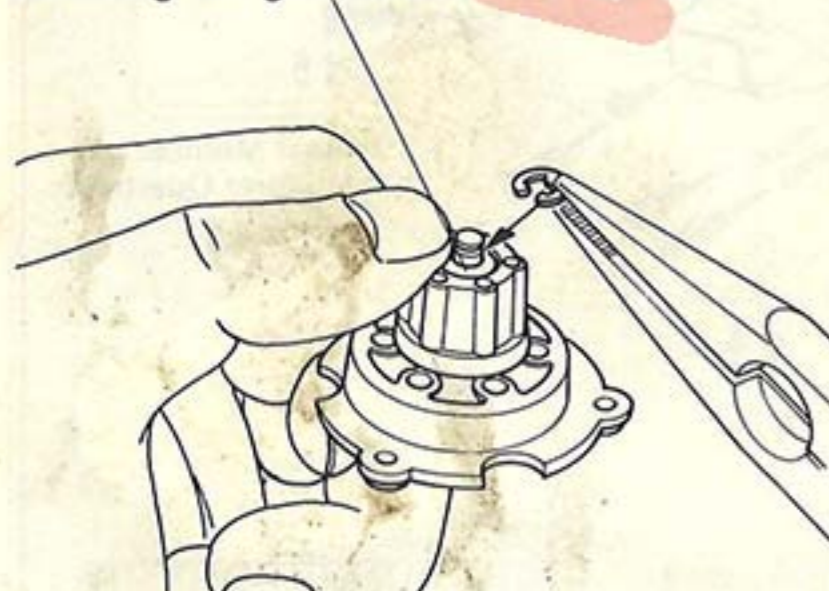

Snap into place in the same manner as you did for c3.

**3** Attaching Leaf Springs  
Einbau der Blattfedern

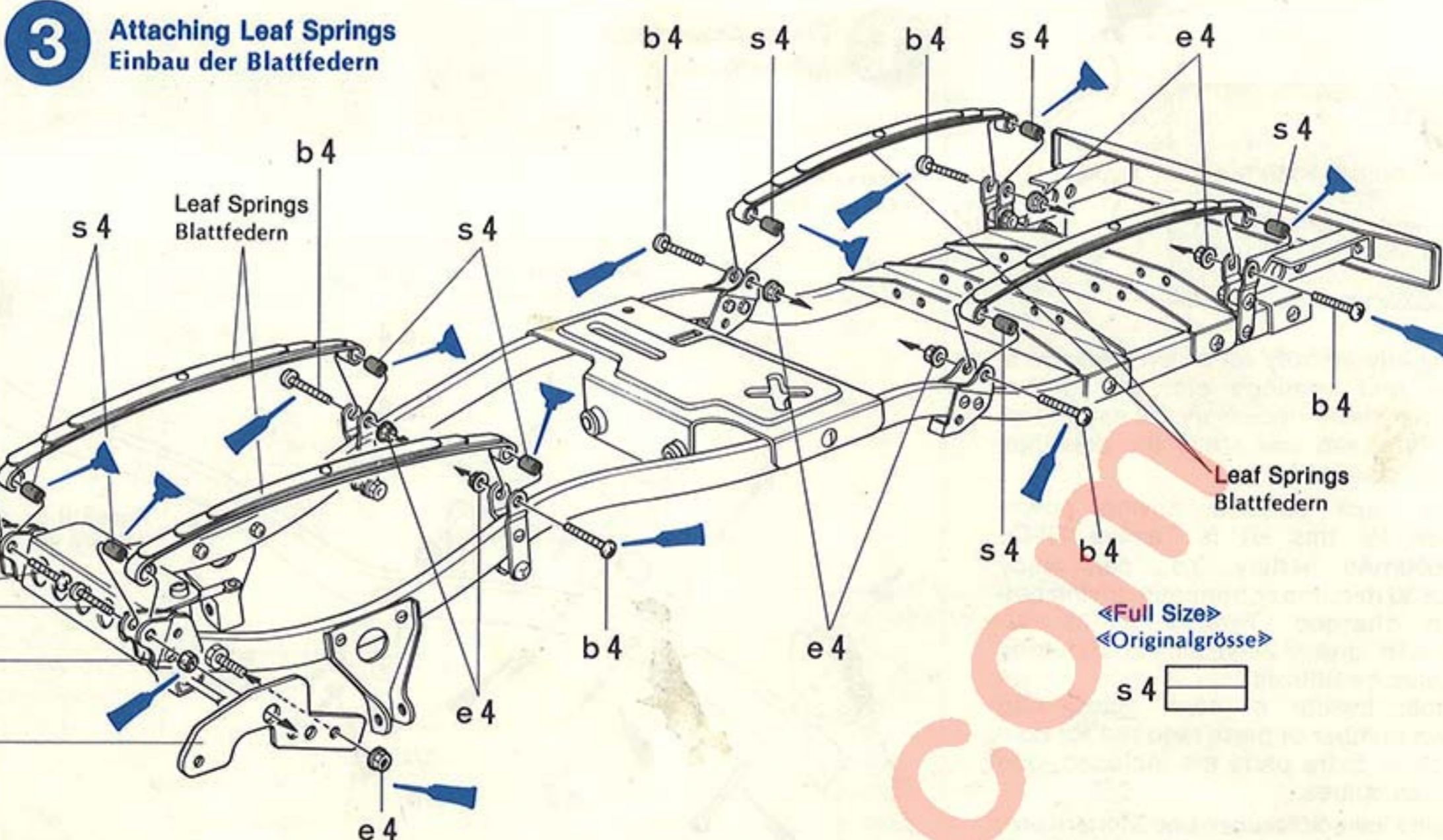

**4** Assembly of Front Axle  
Vorderachse

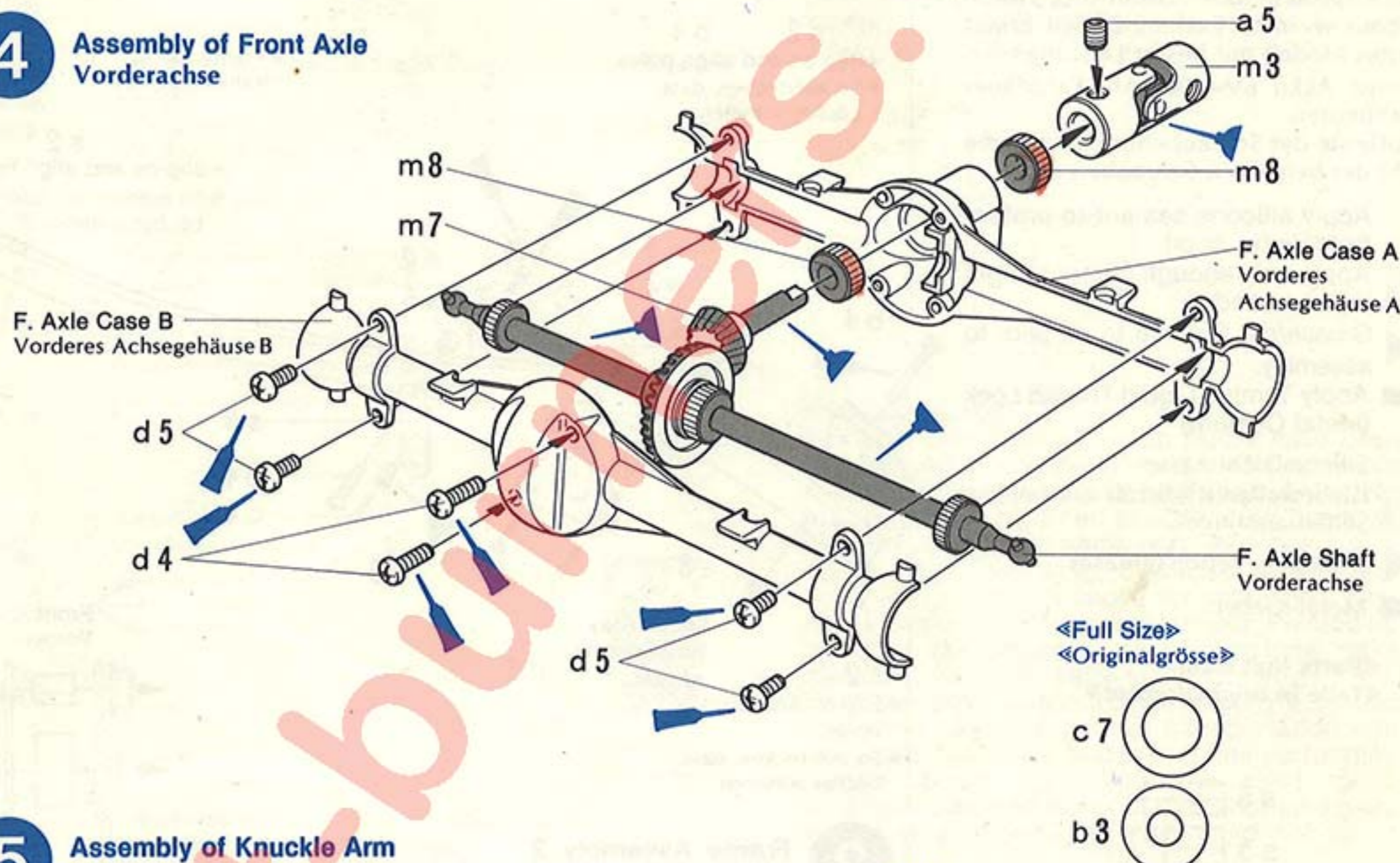

**5** Assembly of Knuckle Arm  
Spurstangenhebel

\*Note turning direction of wheel hub.  
\*Auf Drehrichtung der Rad-Nabe achten.

«Right»  
«Rechts»

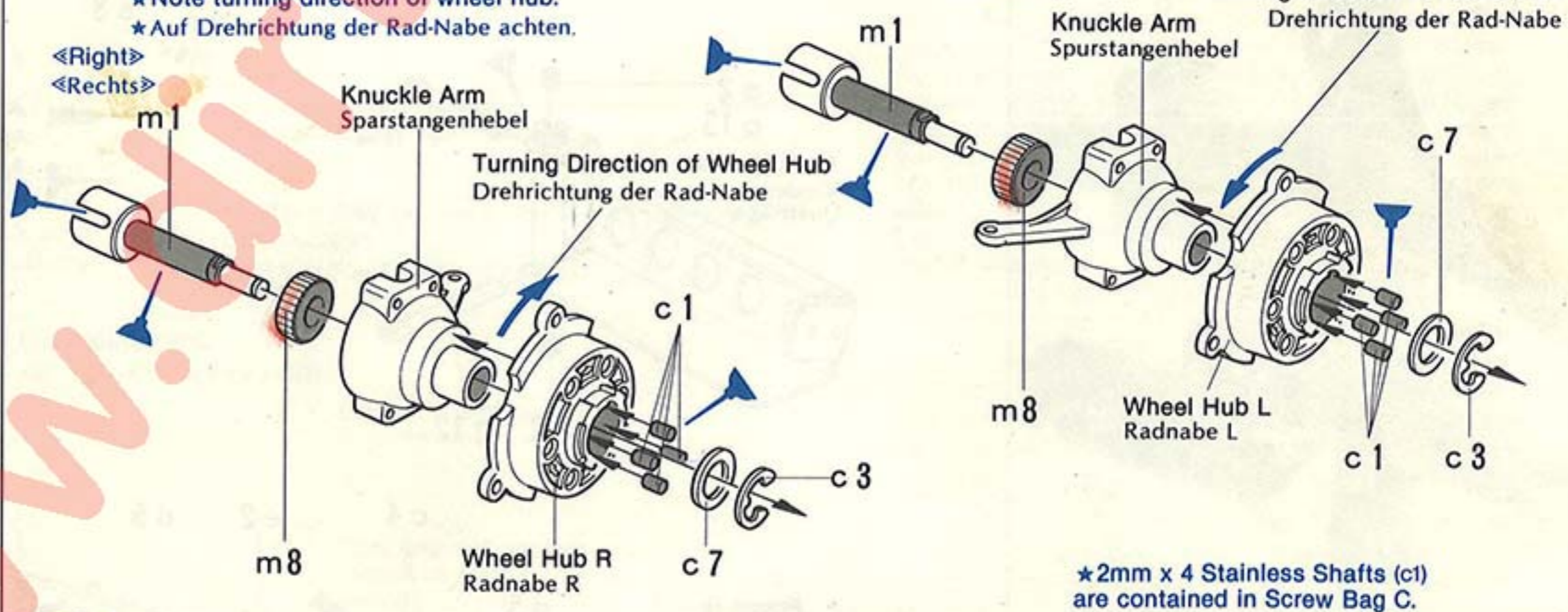

**6** Attaching Hub Caps  
Einbau der Radkappen

«Right»  
«Rechts»

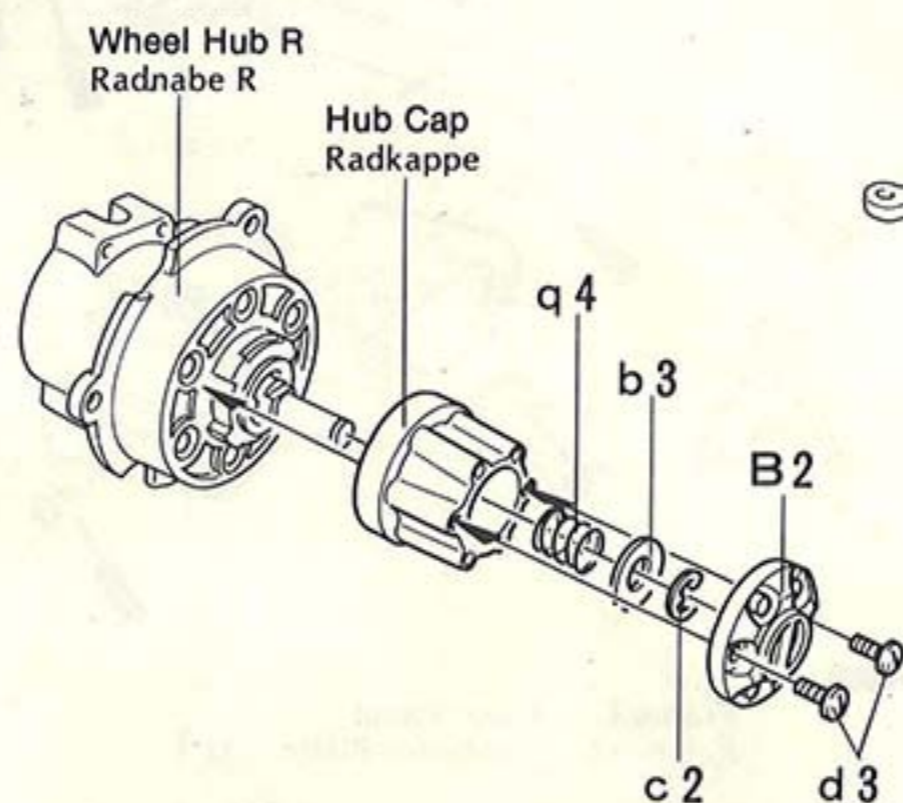

«Left»  
«Links»

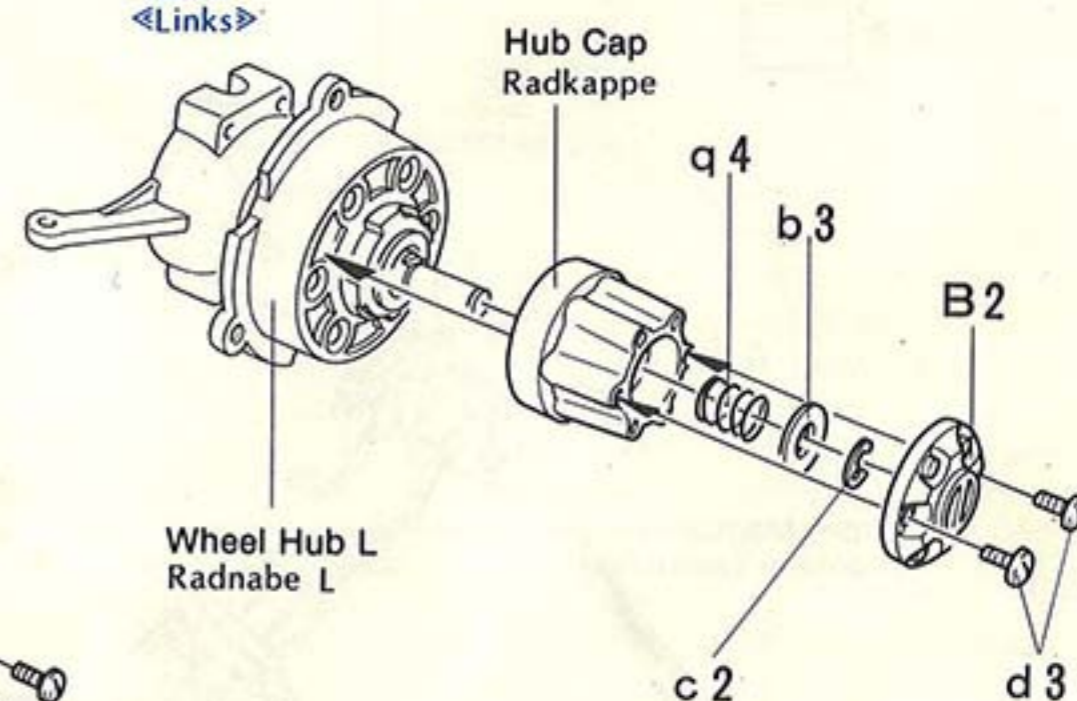

**7** «Assembly of Rods»  
«Schubstangen»

«Steering Rod A»  
«Steuer-Schubstange A»

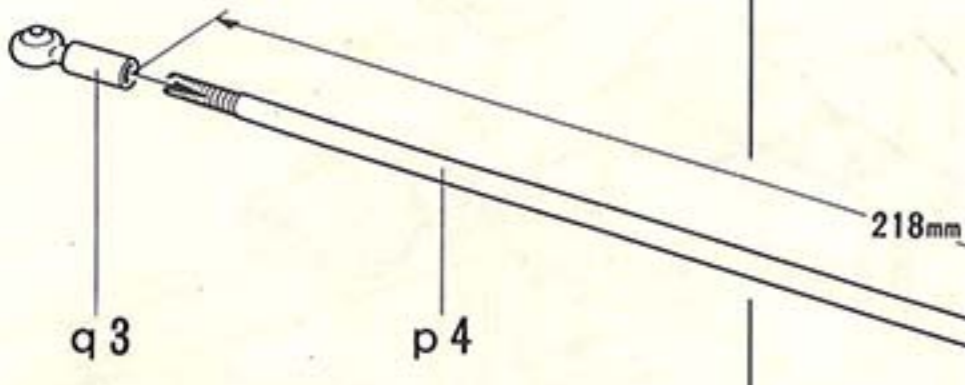

«Lubricating»  
«Schmiere»

Apply a light coat of grease to all moving parts.  
Drehender Teile einfetten um festfressen zu vermeiden.

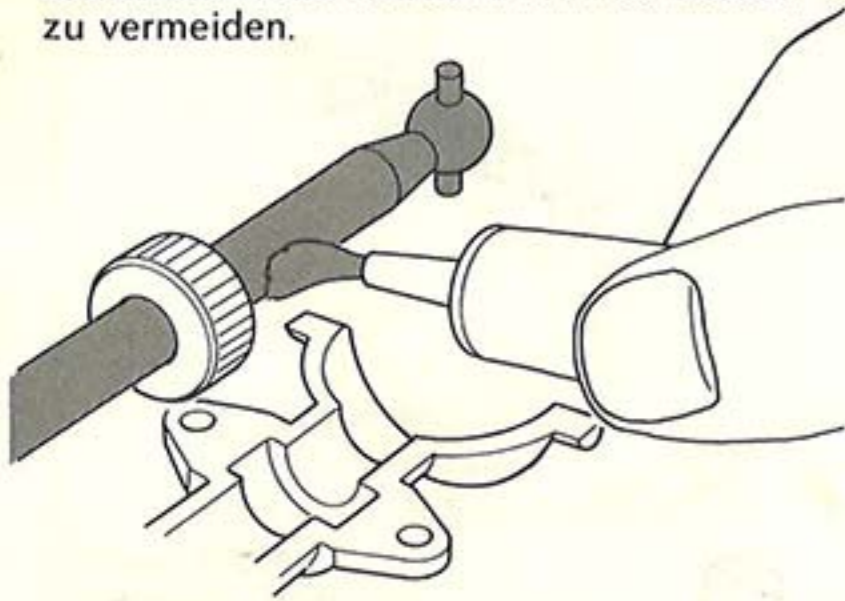

«Seating Universal Joint onto Bevel Shaft»  
«Madenschraube muss in Kerbe sein»

\*Firmly tighten grub screw on flat of bevel shaft.  
\*Madenschraube bis zu Achskerbe einschrauben.

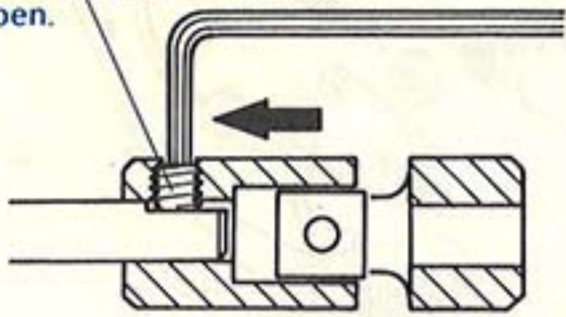

**9** «Completed Rear Axle»  
«Komplette Hinterachse»

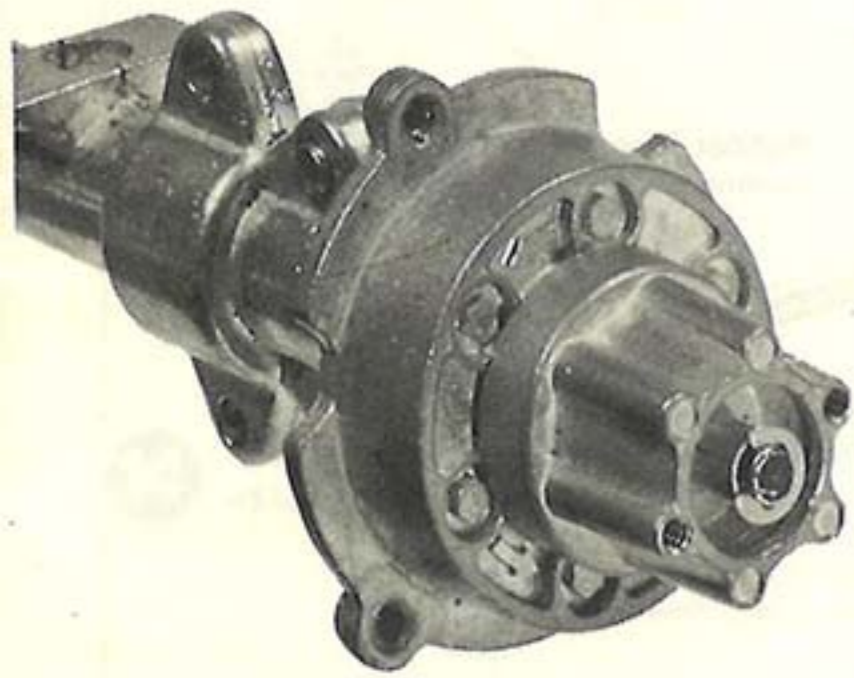

**7** Assembly of Rods  
Schubstangen

«Tie Rod»  
«Lenker-Schubstange»

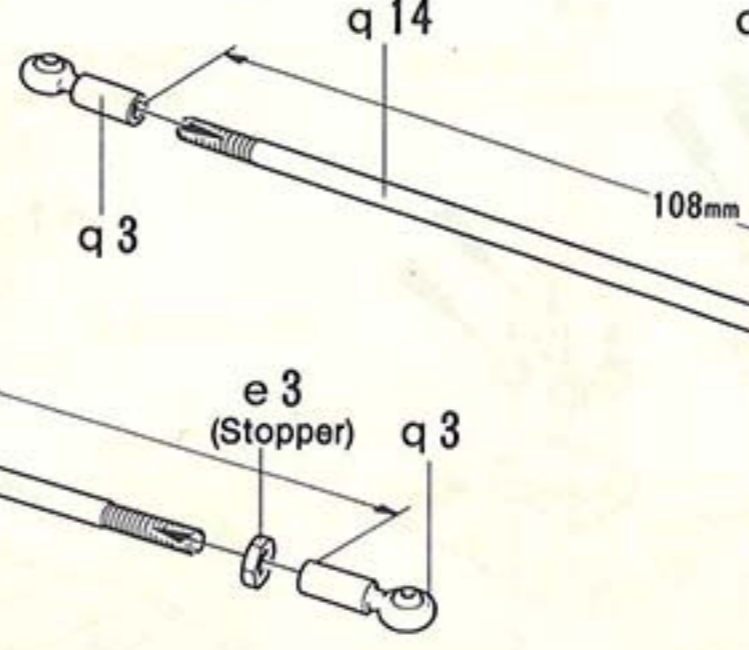

«Steering Rod B»  
«Steuer-Schubstange B»

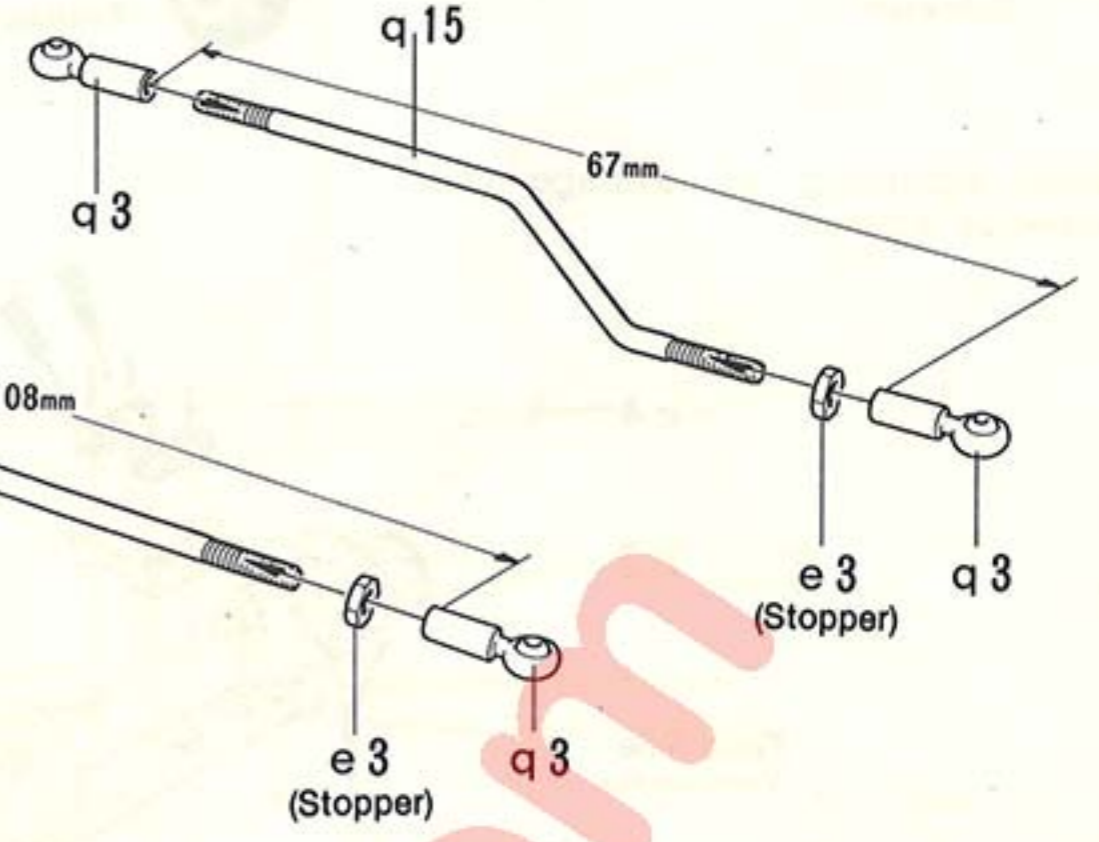

**8** Attaching Knuckle Arms  
Einbau der Spurstangenhebel

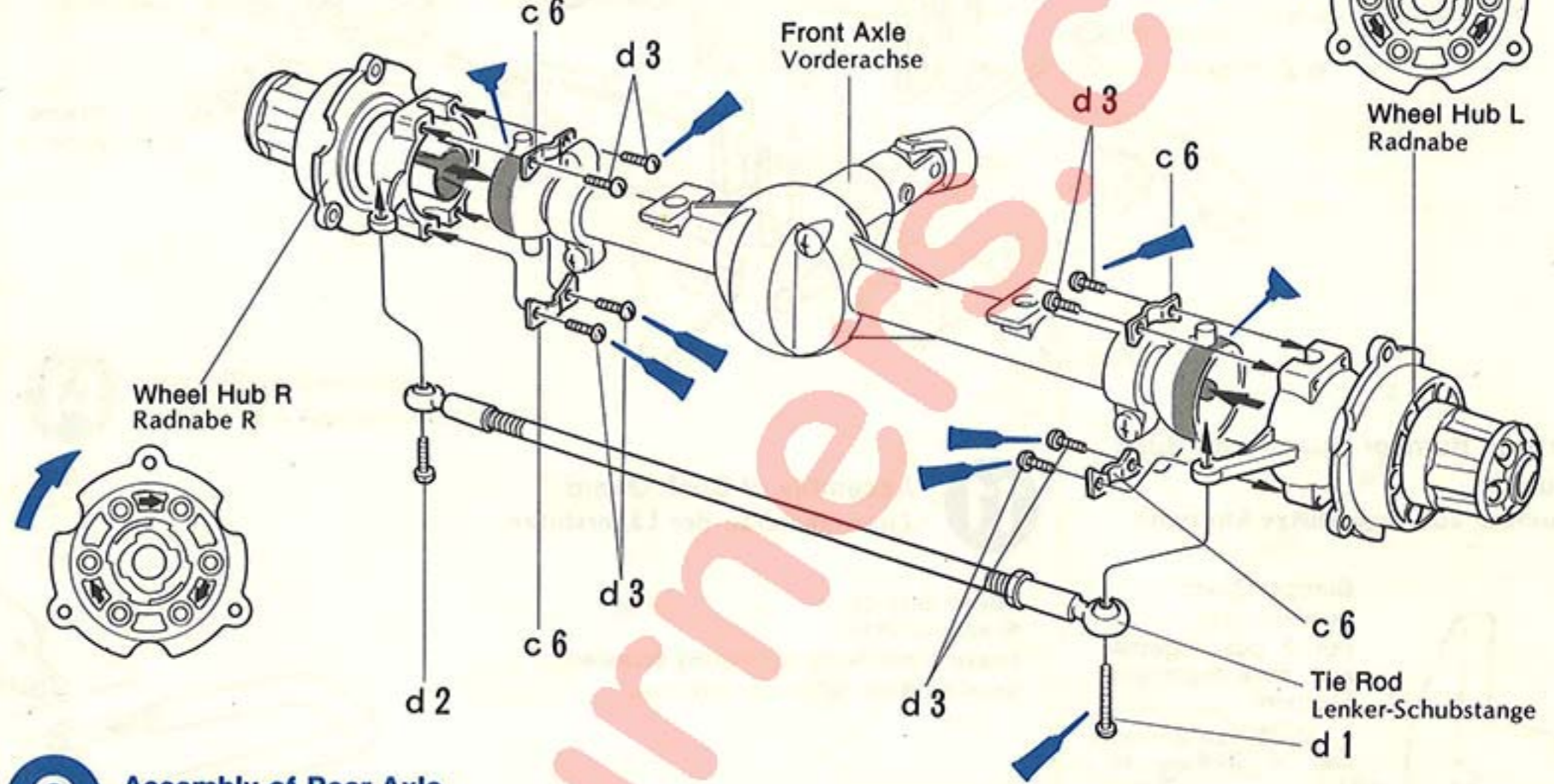

**9** Assembly of Rear Axle  
Hinterrachse

«Step 1»

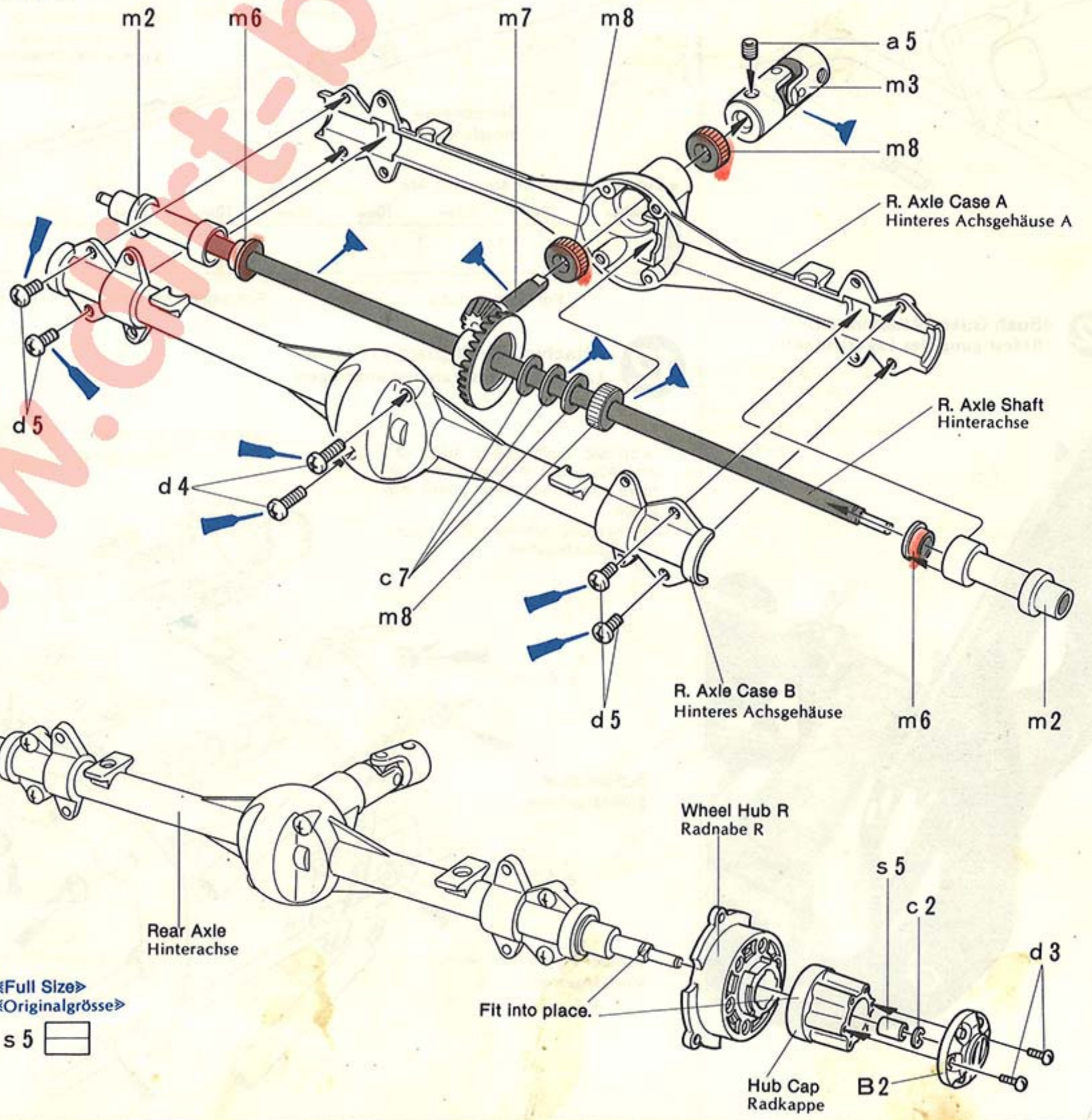

Fit into place.

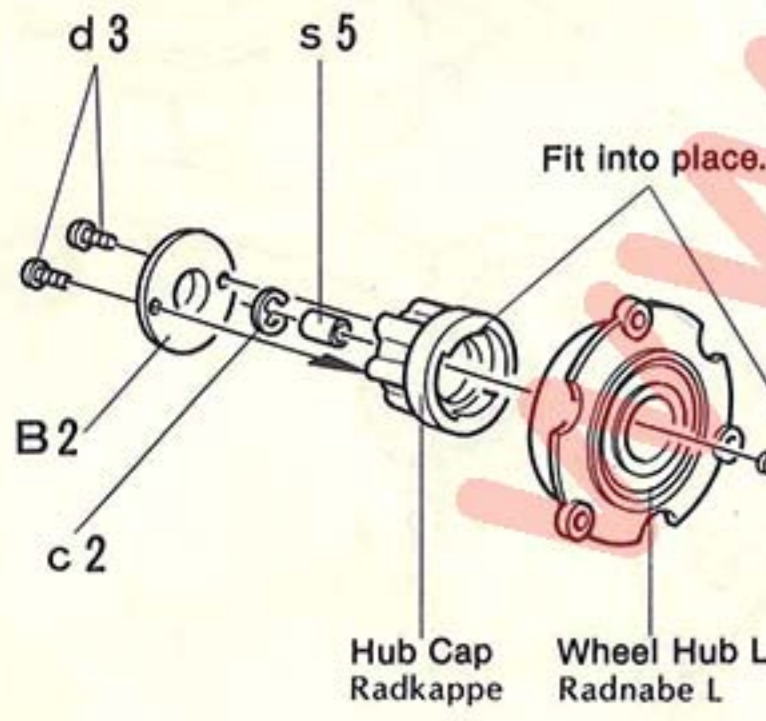

Fit into place.

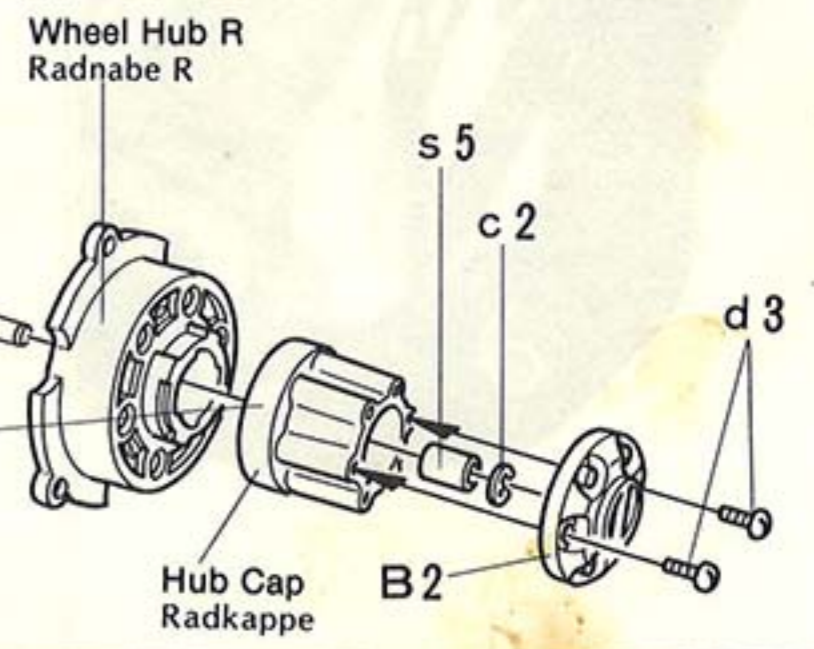

«Full Size»  
«Originalgröße»

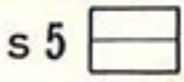

**TAMIYA COLOUR CATALOGUE**  
The latest in cars, boats, tanks and ships. Motorized, radio controlled and museum quality models are all shown in full colour in Tamiya's latest catalogue. At your nearest hobby supply house.

**10** «Mounting Axles onto Frame»  
«Einbau der Vorder und Hinter Achsen»

★When tightening e4, average your power on 4 nuts.

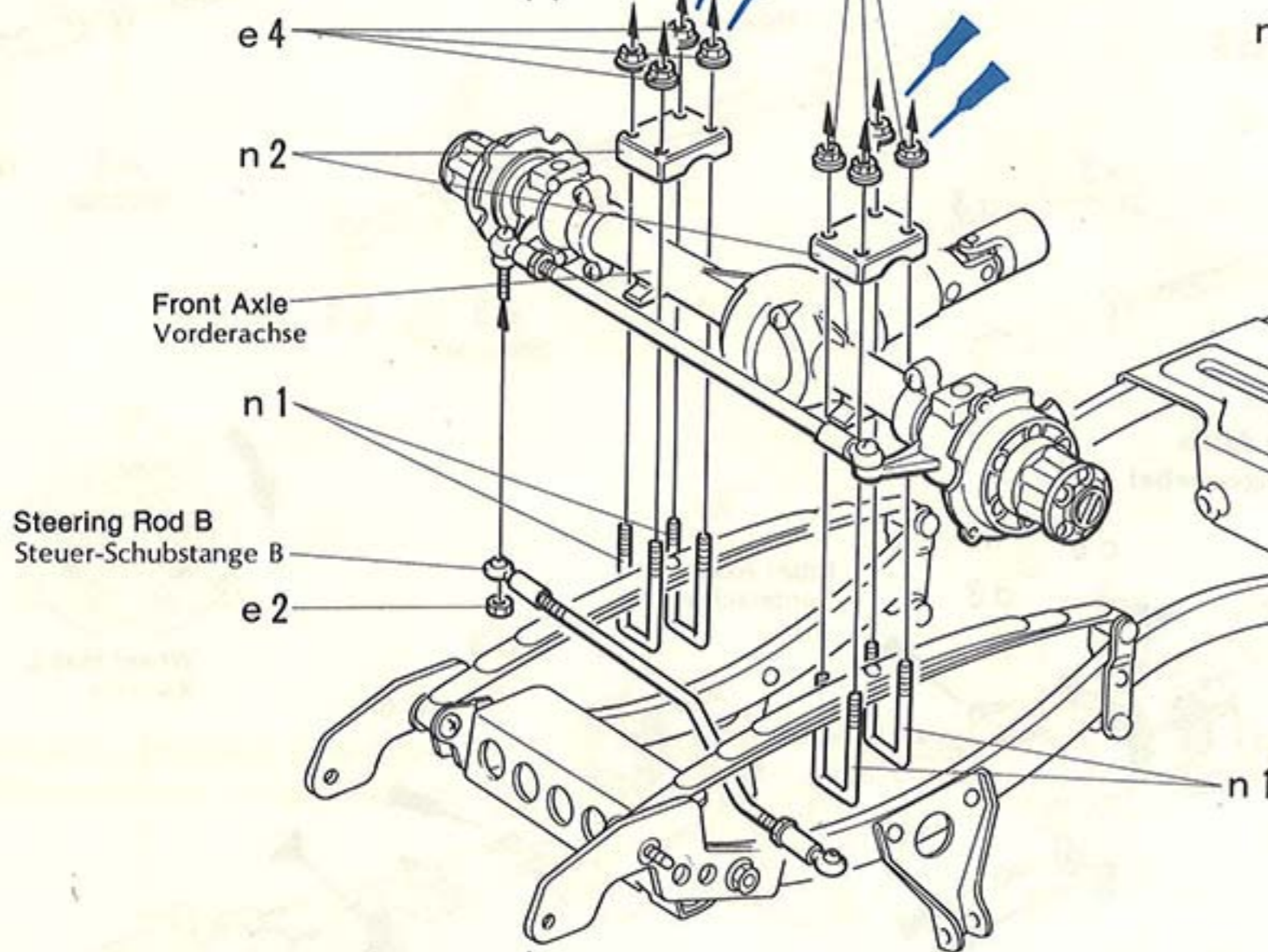

**10** Mounting Axles onto Frame  
Einbau der Vorder und Hinter Achsen

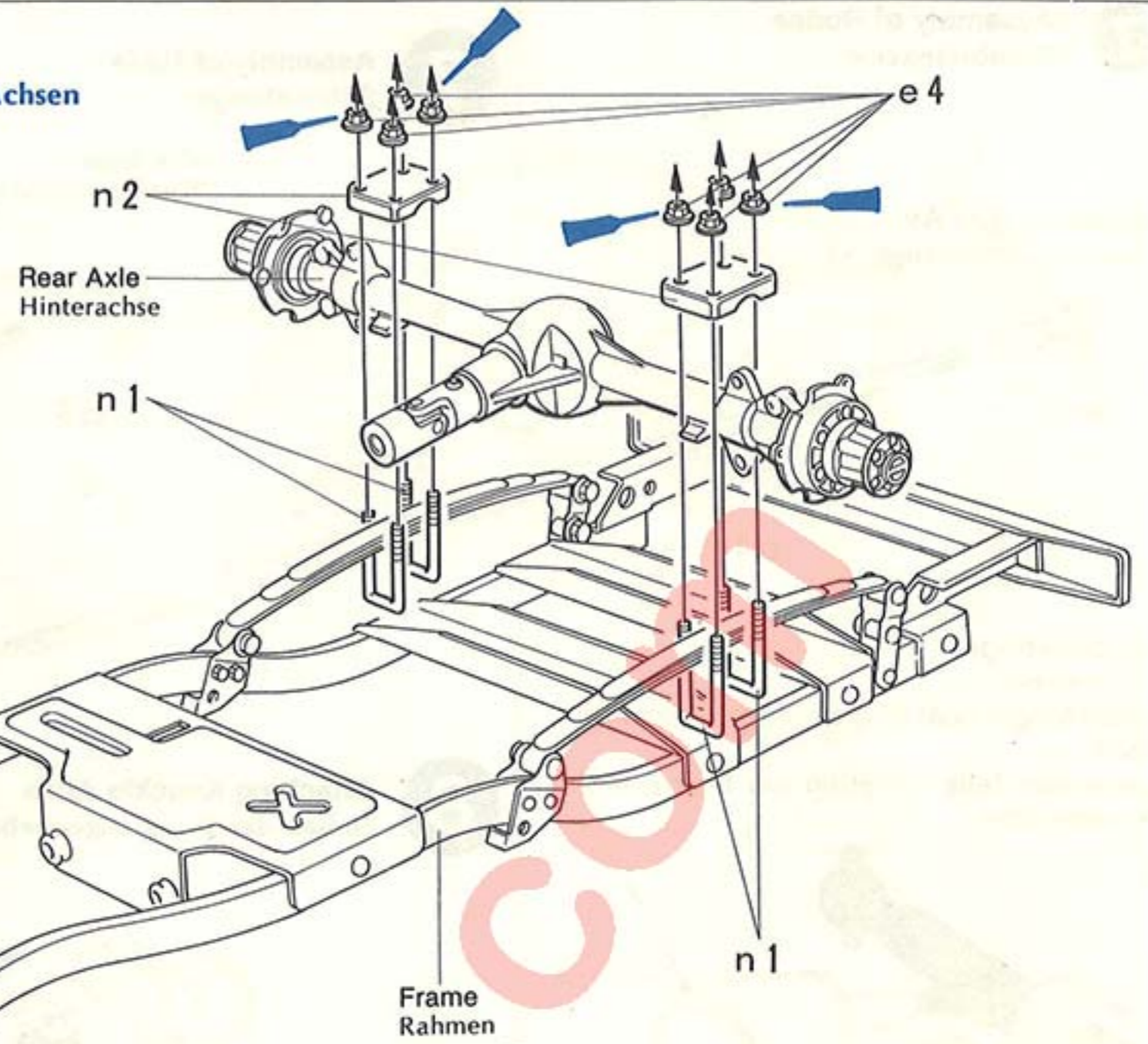

**11** «Driving Bumper Guard onto Bush Guard»  
«Bumber auf Lagerstütze klopfen»

Bumper Guard  
Bumberstütze  
Put 2 pcs together  
and drive them into  
position.  
2 Stück zusammen  
und in Stellung  
bringen.

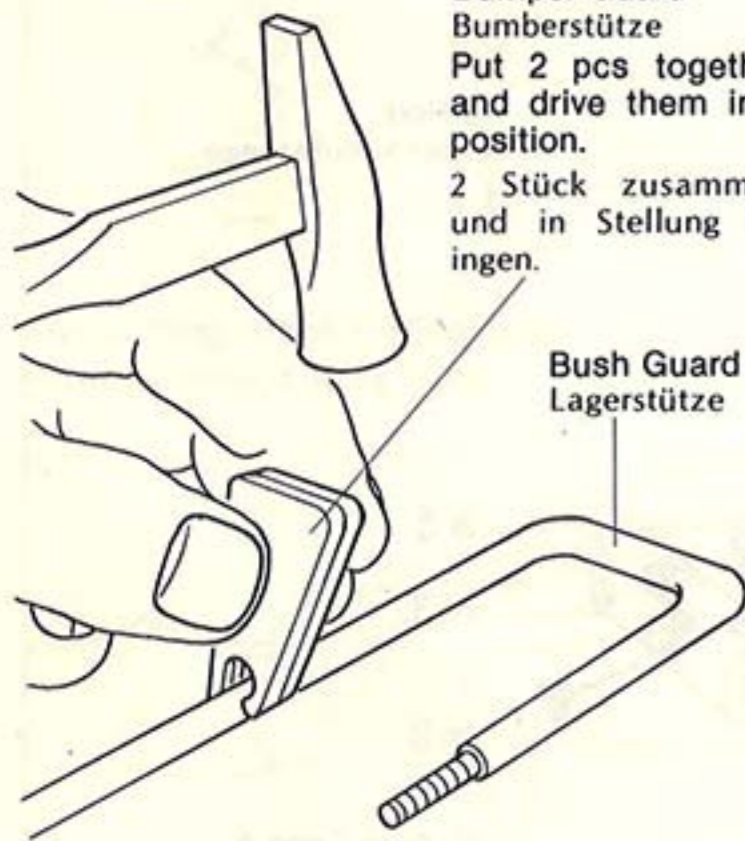

**11** Assembly of Bush Guard  
Zusammenbau der Lagerstütze

«Bush Guard»  
«Lagerstütze»  
Leave 4 mm Nuts (a6) lightly screwed.  
4mm Muttern (a6) leicht anziehen.

«Bumper Pipe»  
«Stossfängerrohr»

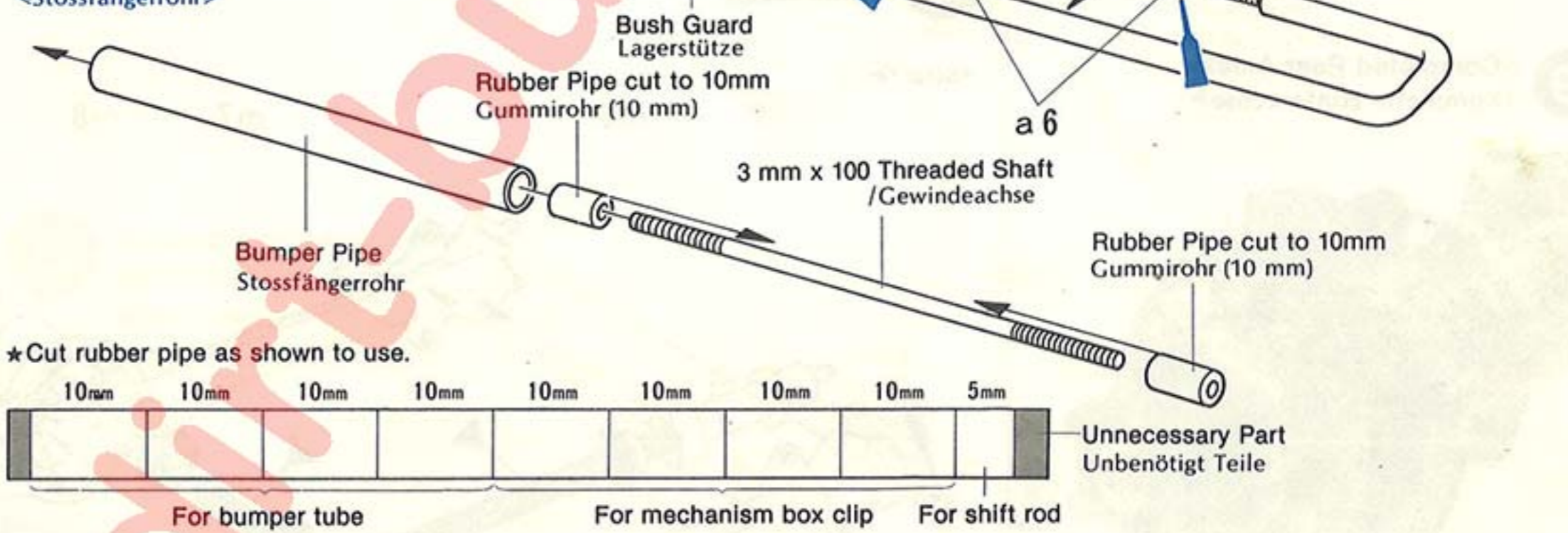

★Cut rubber pipe as shown to use.

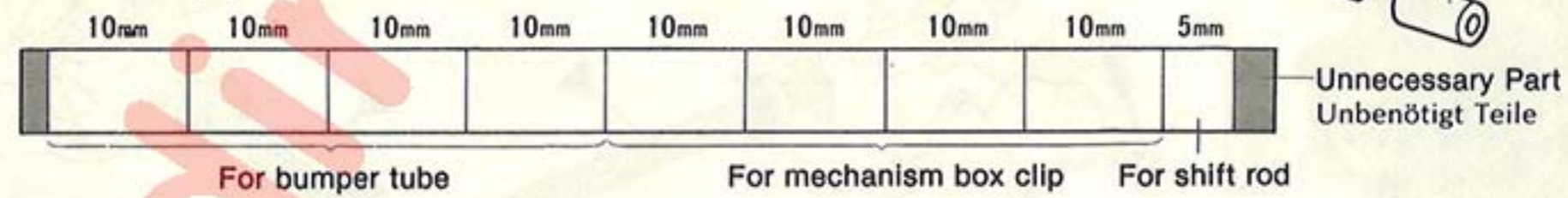

**12** «Bush Guard Attachment»  
«Befestigung der Lagerstütze»

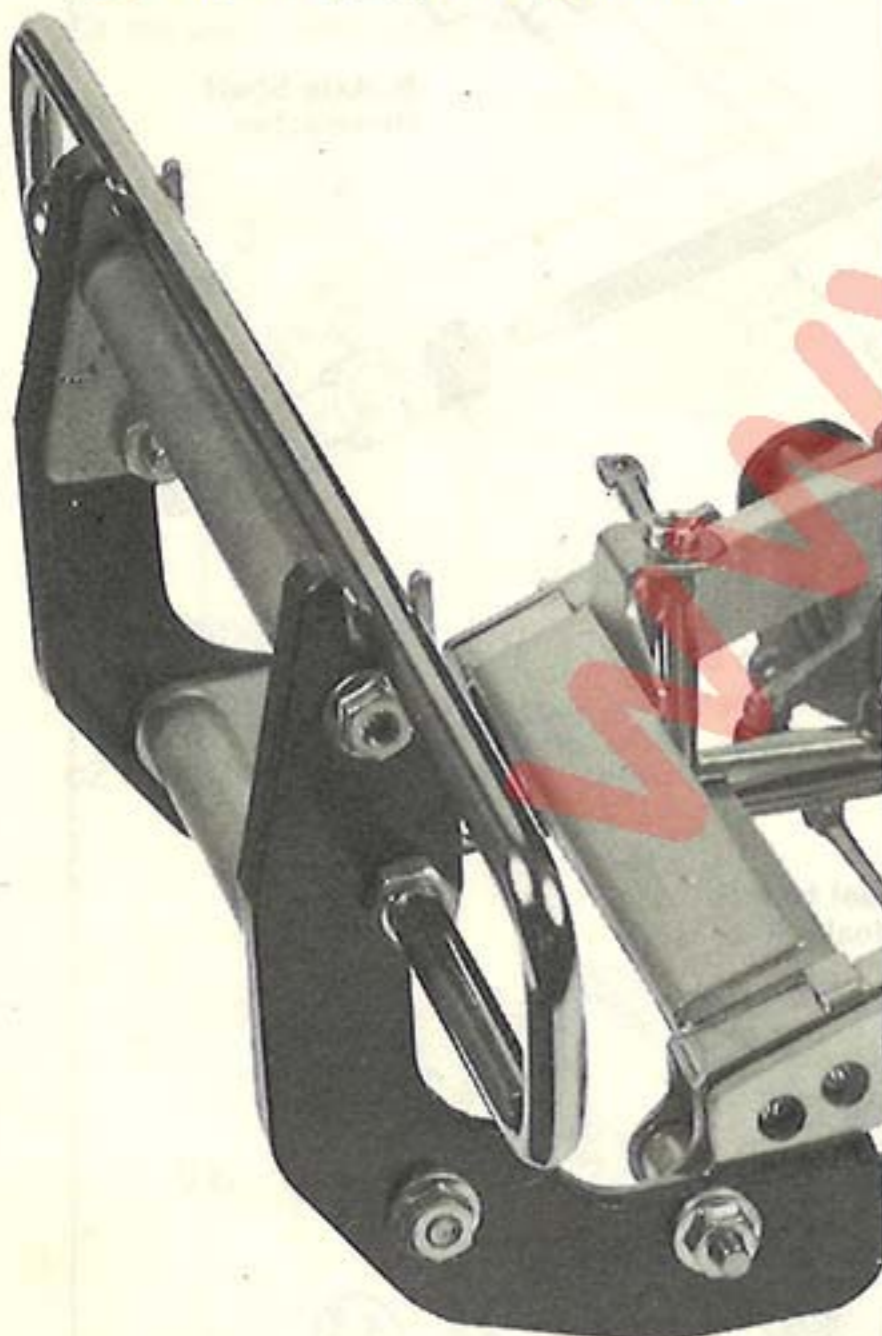

**12** Attaching Bush guard to Frame  
Lagerstütze im Rahmen anbringen

★Spread bush guard stays (A1 and A2) apart in direction of arrows and attach bush guard into place.  
Pfeilrichtung dehnen und an Lagerstütze anschrauben.

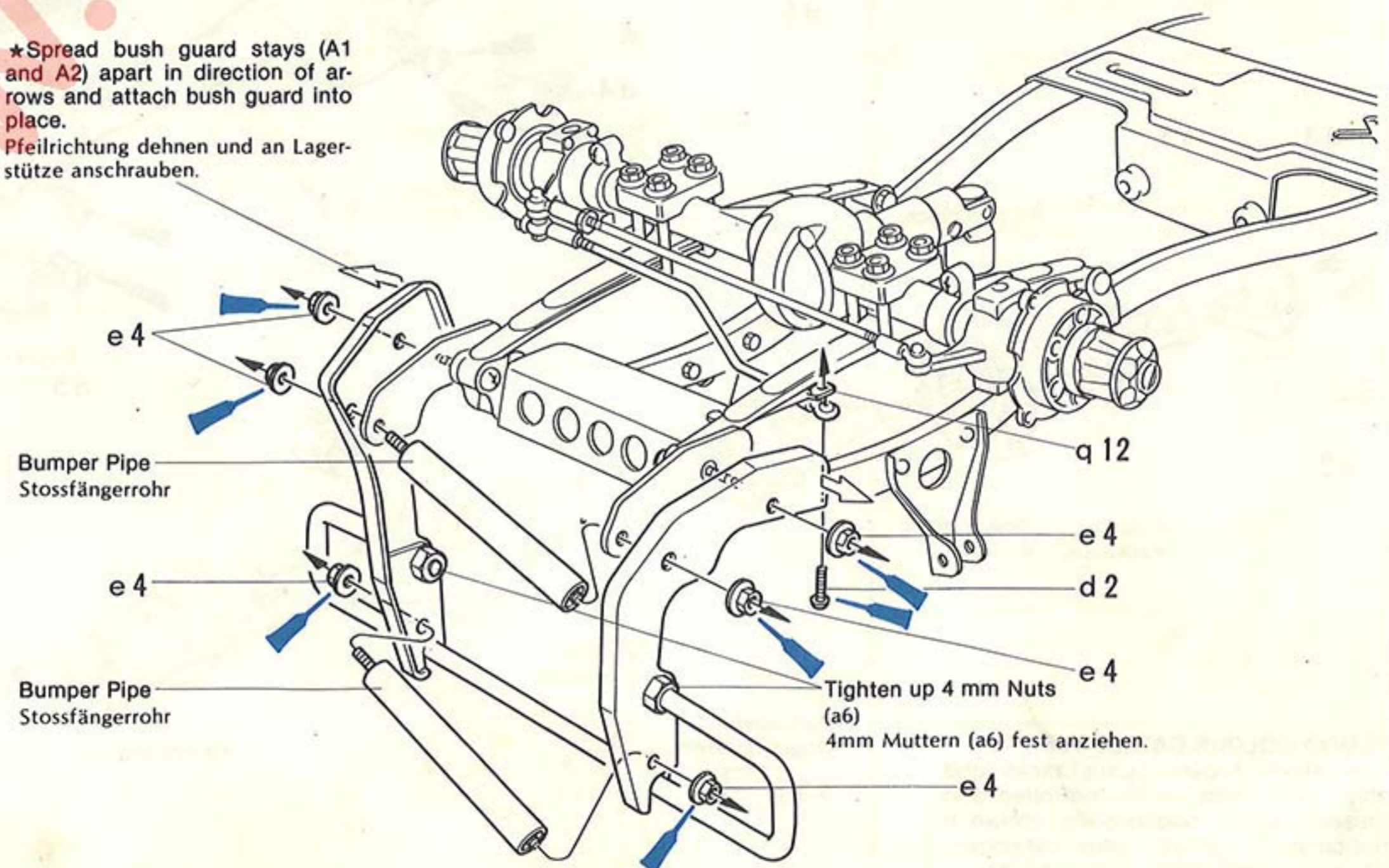

**13** <Waterproofing Gear Box>  
<Abdichten der Getriebe Box>

Apply silicone sealant to joints of gear box, then wipe off excess with a dry cloth.

Silicon Dichter an die Verbindungen der Getriebe Box auftragen, Überreste mit trockenem Lappen abwischen.

Apply silicone sealant.  
Silicon-Dichtmasse

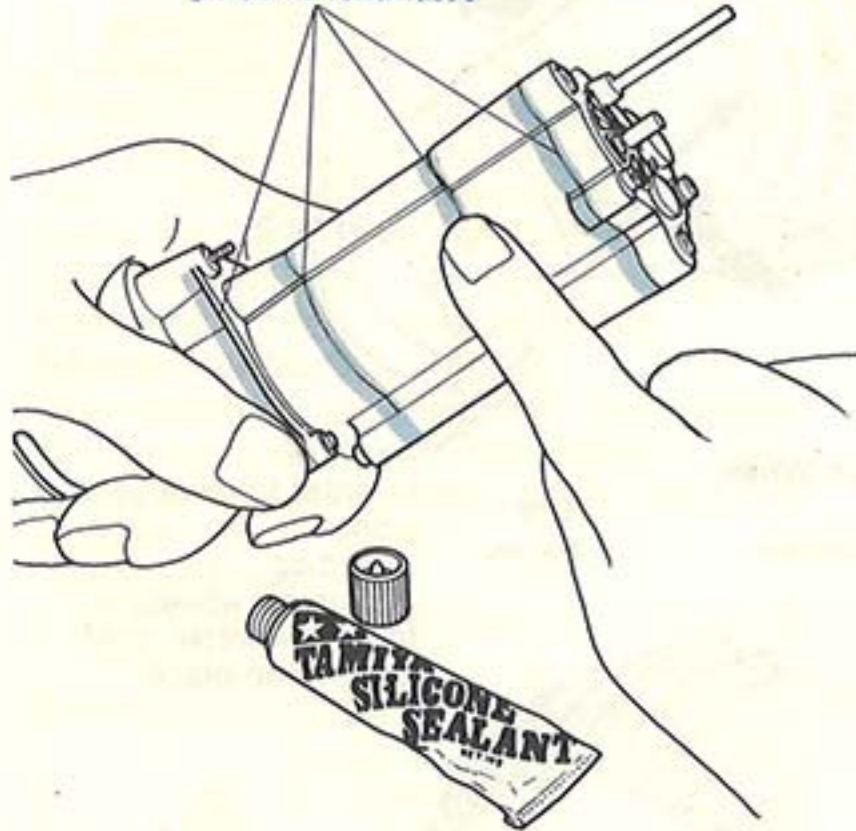

<Gear Test>  
<Getriebe Testlauf>

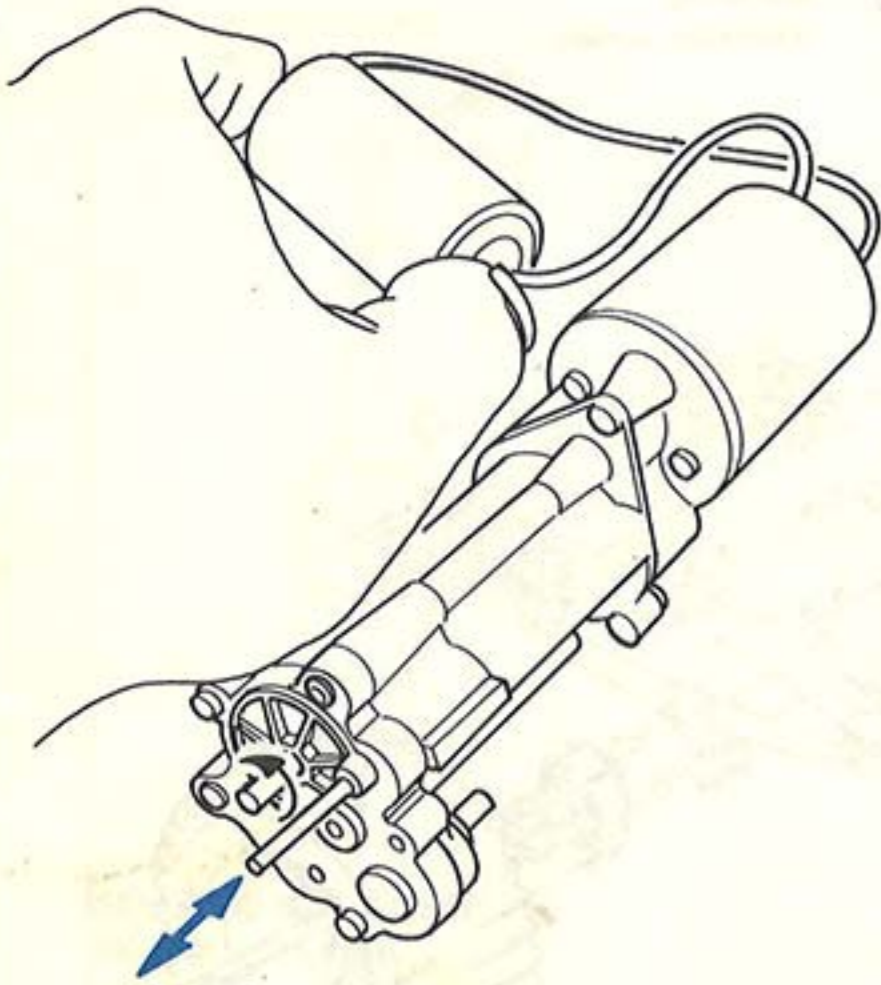

**14** <How to fasten Propeller Shafts>  
<Einbau der Gelenkwelle>

\*Pull the shaft to full length and fasten with grub screw (a2).  
\*Kardanachse ganz einstecken und mit Madenschraube a2 festschrauben.

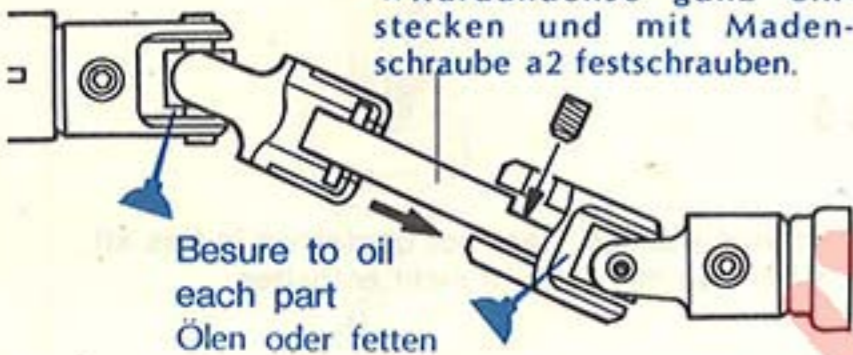

Besure to oil each part  
Ölen oder fetten

**15** <Resistor>  
<Widerstand>

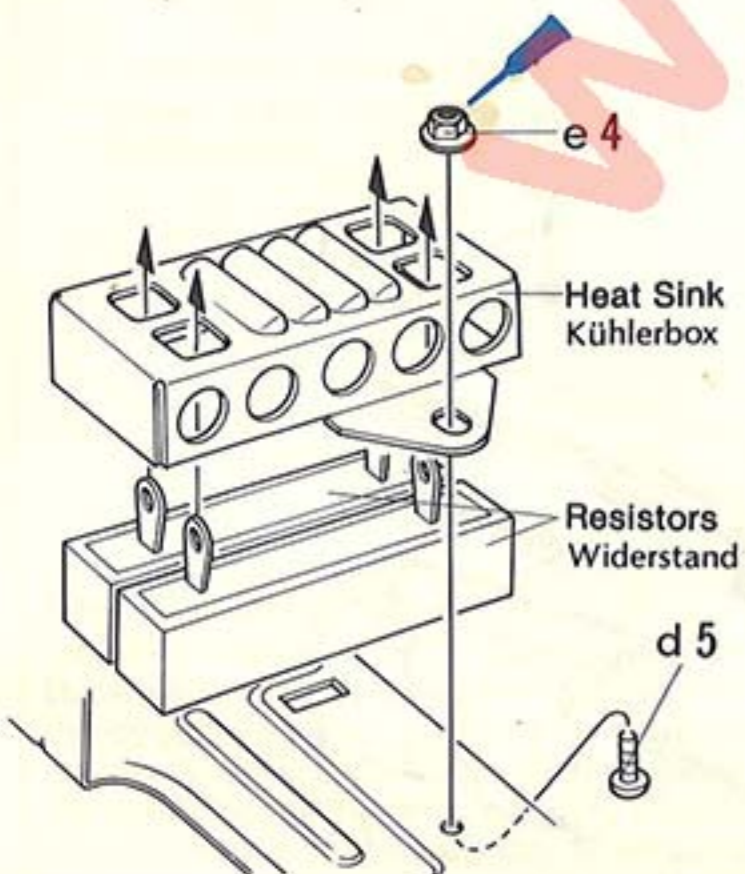

**13** Gear Box Outer Parts  
Getriebe Gehäuse

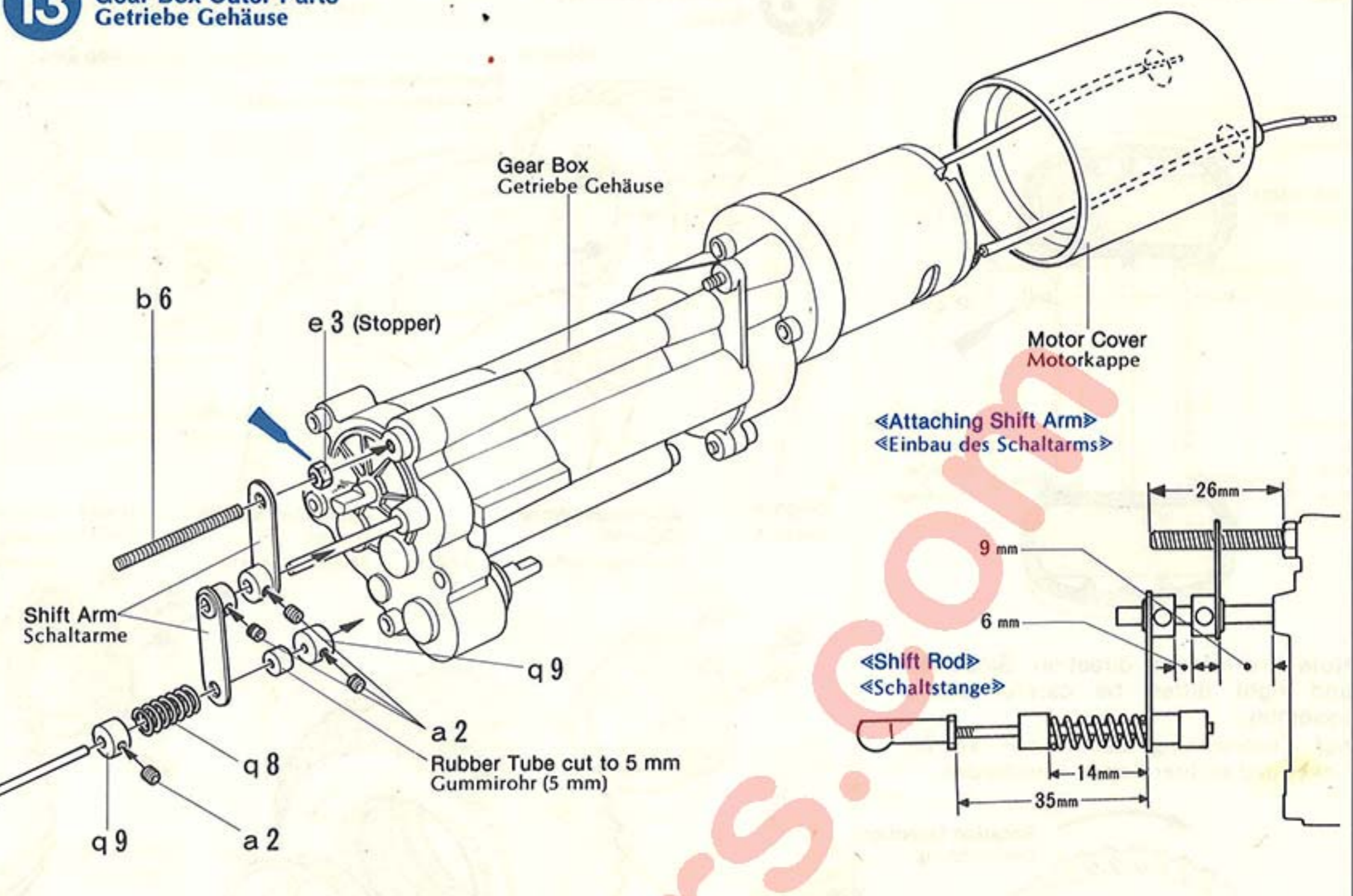

**14** Installing Gear Box  
Einbau des Getriebe Gehäuses

<Full Size>  
<Originalgrösse>

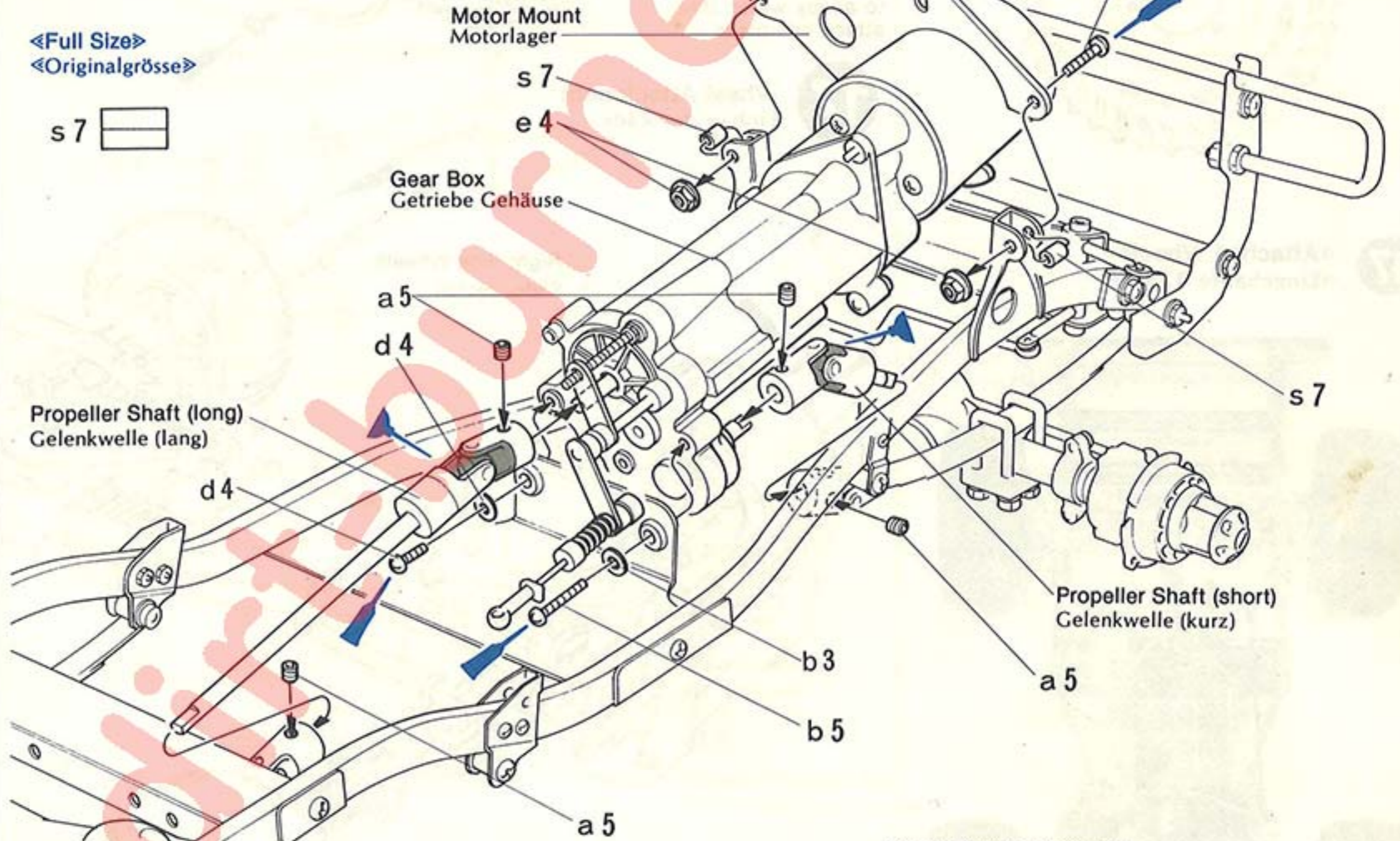
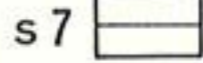

**15** Attaching Resistors  
Widerstand

Attach t8 by tightening d5 at the top of holes.  
Karosseriehälter anschrauben, Splintlager fest anziehen.

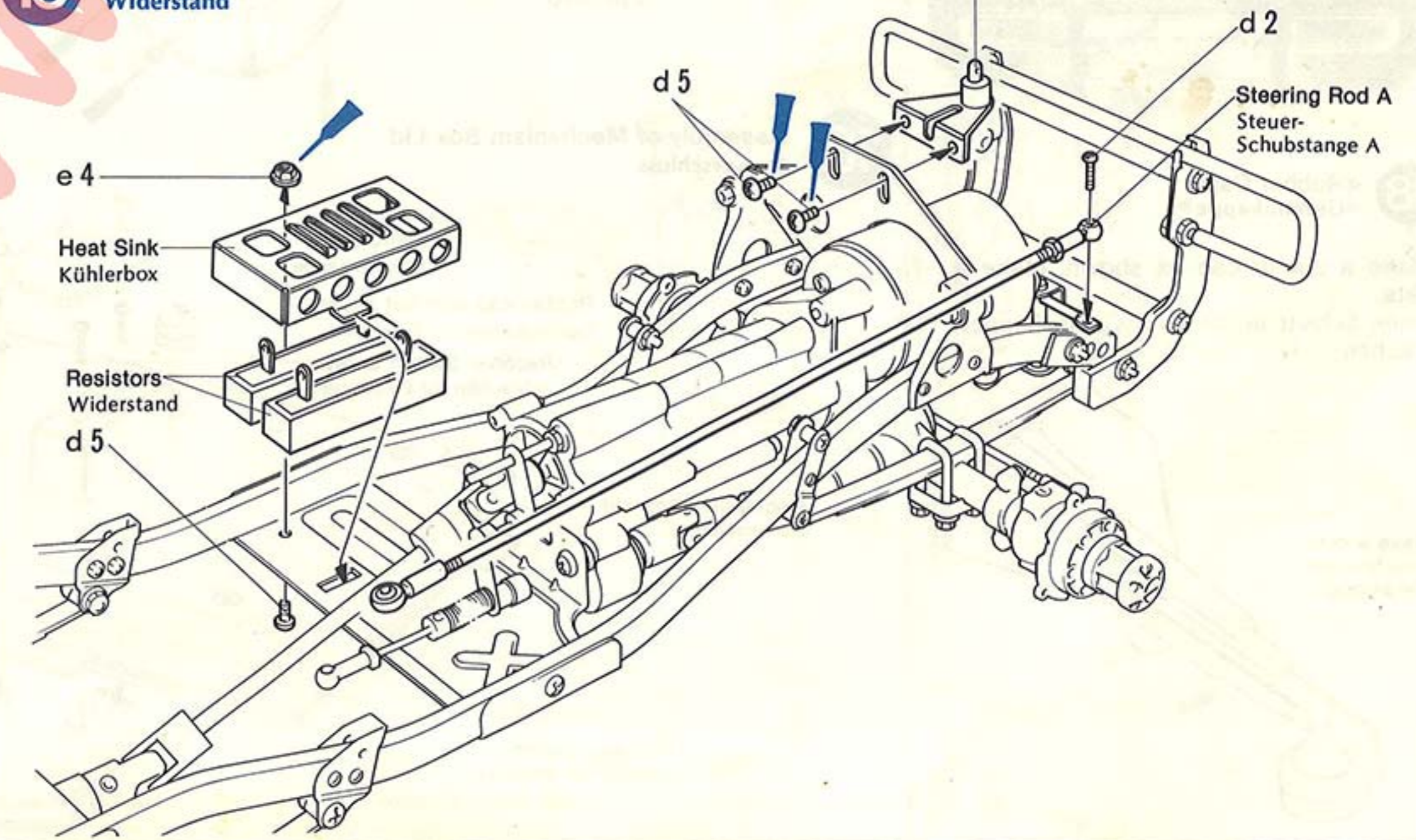

**16** «Cross Section of Wheel»  
«Querschnitt Rad»

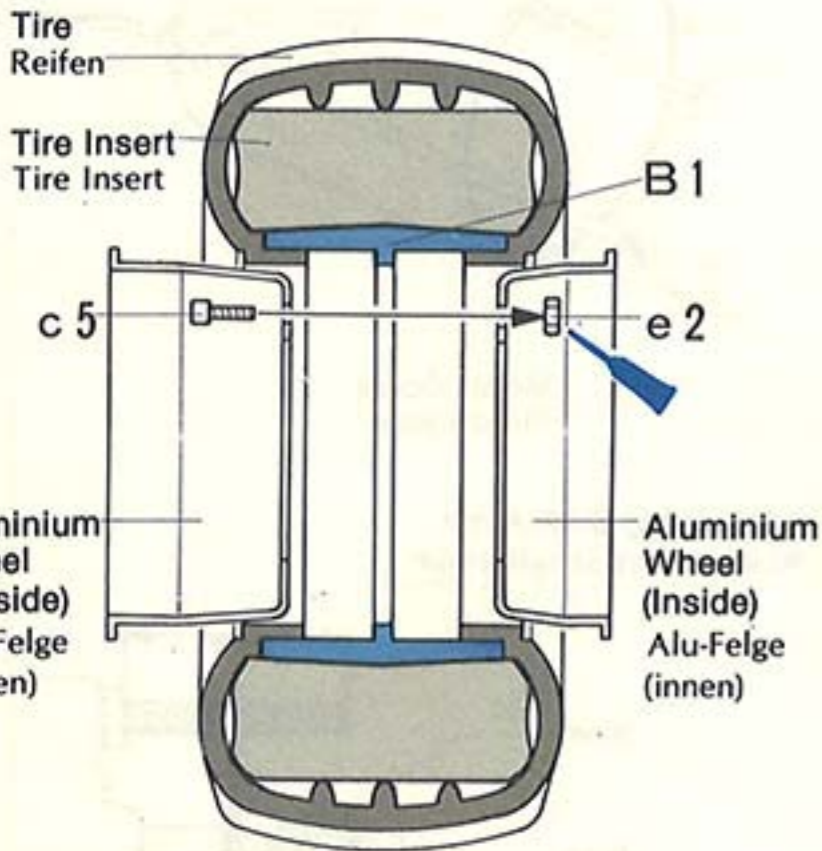

Note tire rotation direction. Since left and right differ, be careful during assembly.  
Auf Drehrichtung der Reifen achten. Linker und rechter Reifen verschieden.

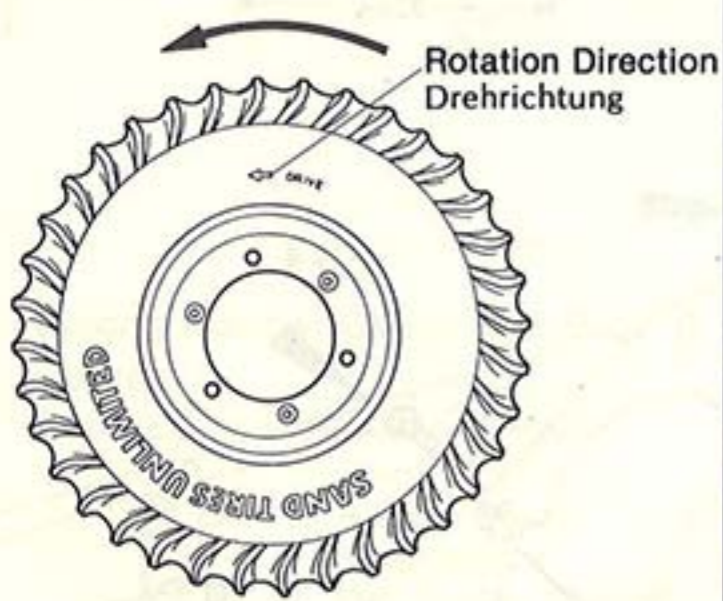

**17** «Attached Wheels»  
«Eingebaute Räder»

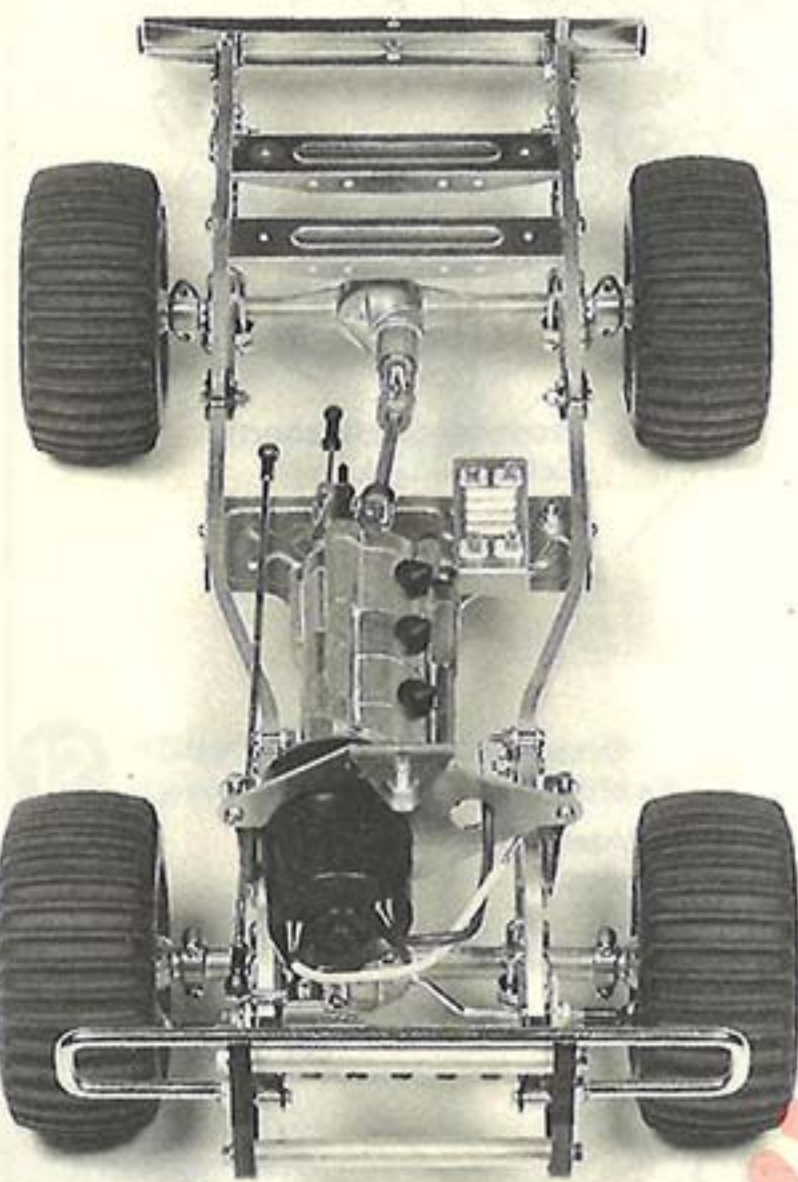

**18** «Rubber Cap»  
«Gummikappe»

Make a cut to cap as shown. Make 2 sets.  
Einen Schnitt in die zwei Gummikappen machen.



**16** Wheel Assembly  
Räder

\* Make up 2 left and 2 right.  
\* Je 2 Räder für linke und rechte Seite machen.

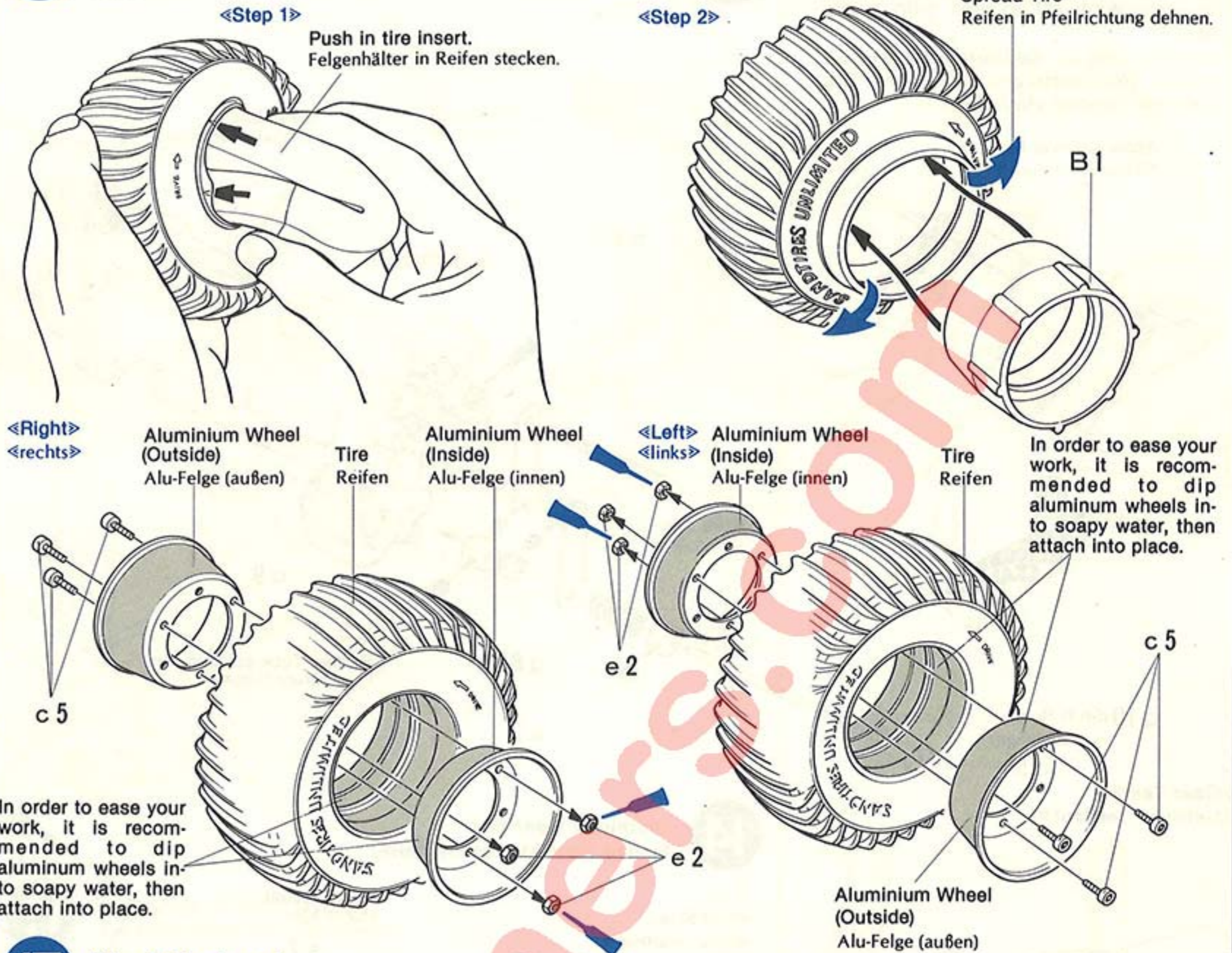

**17** Wheel Attachment  
Einbau der Räder

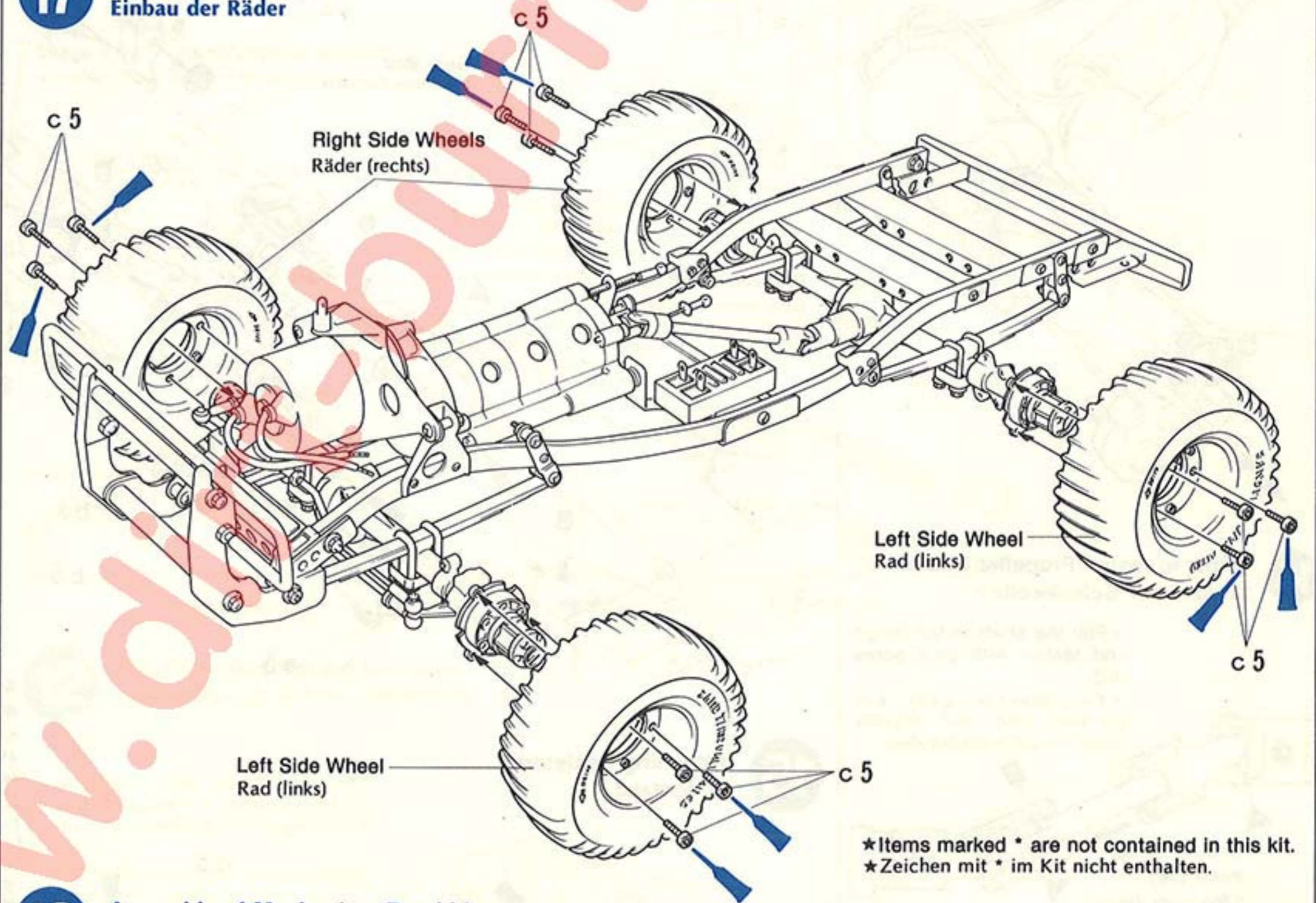

\*Items marked \* are not contained in this kit.  
\* Zeichen mit \* im Kit nicht enthalten.

**18** Assembly of Mechanism Box Lid  
Boxverschluss

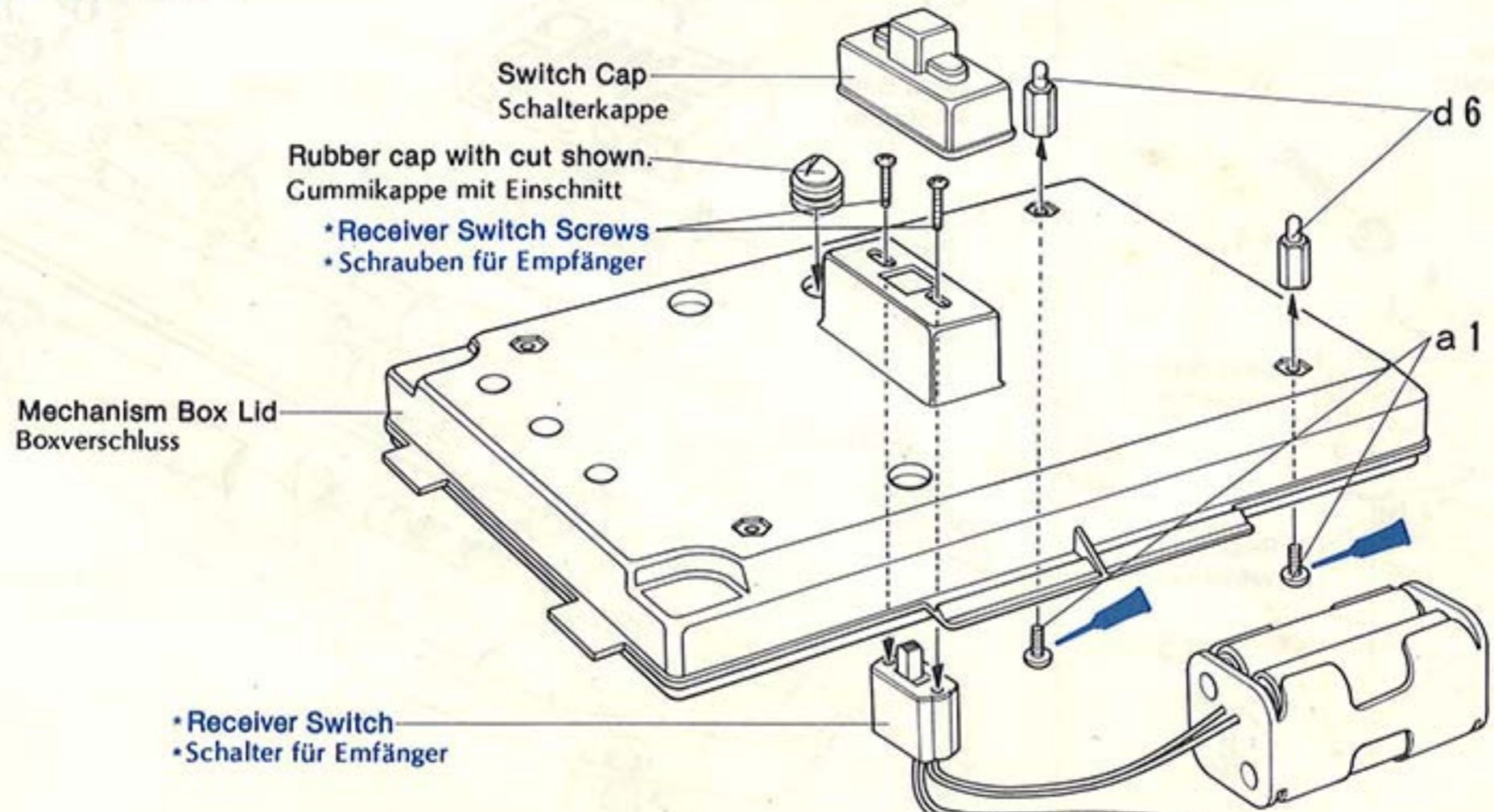



«Radio Control Mechanism»

This kit is designed for 4 channel 3 servo RC units. Use two clockwise rotation servos for steering and gear shifting, and use a counter-clockwise rotation servo for speed control.

If your RC unit has choice of clockwise or counter-clockwise rotation on each servo, set the switch servo to rotate counter-clockwise, and if your rubber grommet has eyelets, remove them prior to servo installation.

«RC Mechanismus»

Dieser Kit ist für 4 Kanal mit 3 Servos geeignet. 2 Servos mit Drehung nach rechts für Steuerung und Gangschaltung, eines mit linker Drehung für den Schalter. Metallösen aus den Befestigungsgummitüllen der Servos entfernen.

«Servo Horns»

The shape of servo control horn varies from manufacturer to manufacturer. Cut off shaded area of your servo horns as shown.

«Servo-Hörner»

Je nach Hersteller sind die Servo-Hörner in verschiedener Form. Die Löcher der Hörner sind für die Feineinstellung.

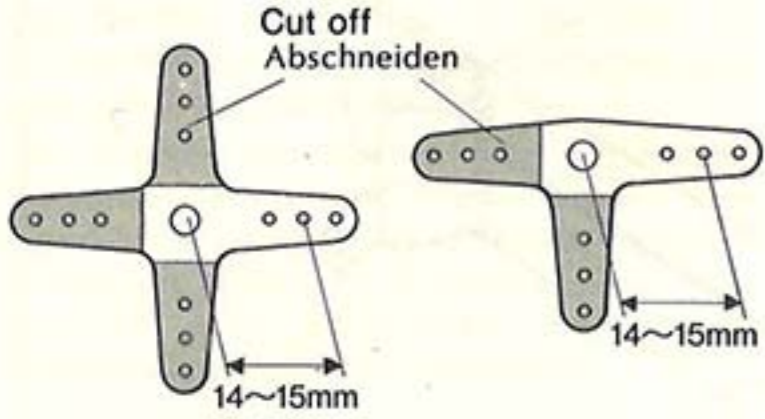

20 «Servo Saver»  
«Servo Lenkarm»

★ Make 2 sets.  
★ 2 Satz machen.

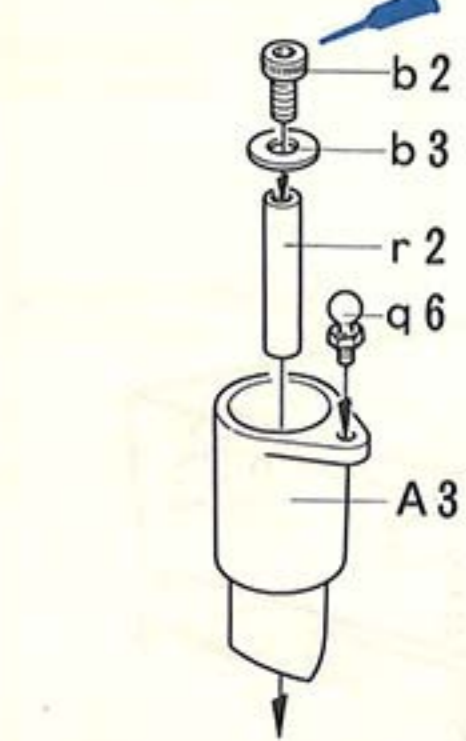

«Feeding out Wires»  
«Kabelführung»

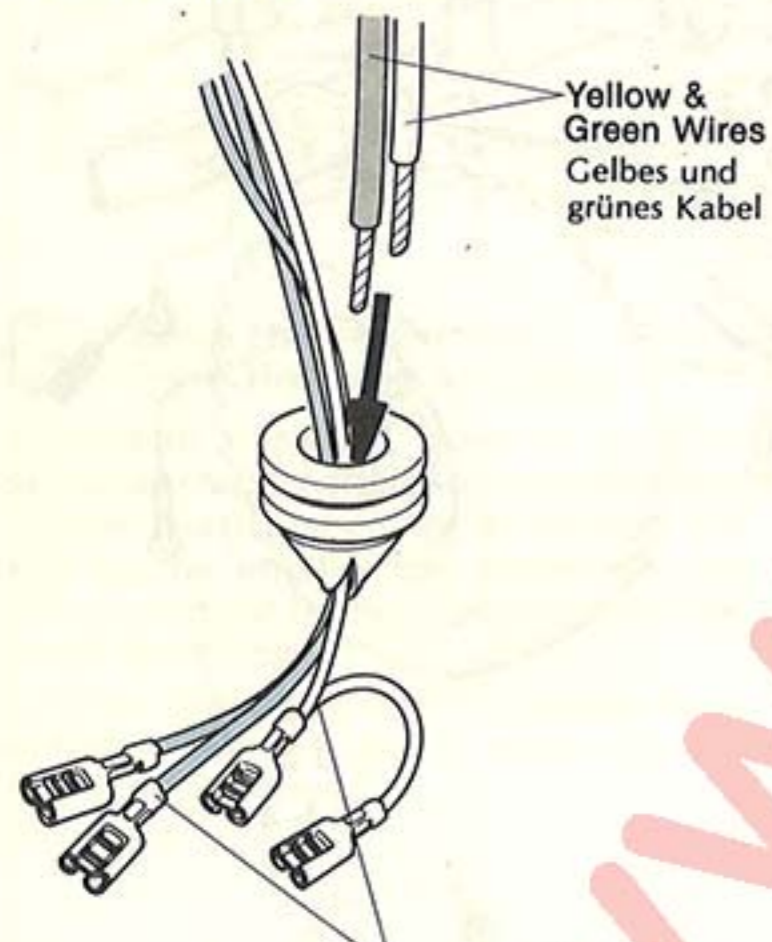

Feed these wires out first one by one. Diese Kabel zuerst herausführen nacheinander.

**TAMIYA'S R/C GUIDE BOOK**  
Tamiya's latest Radio Control Guide Book can make you a winner at the racing circuit. Read up on the latest tune up methods, care and maintenance, painting and decorating your cars. Available at your nearest hobby supply house.

19 Servo Stay Assembly  
Servolager

★ Arrange servos as shown.  
★ Servos wie folgt einbauen.

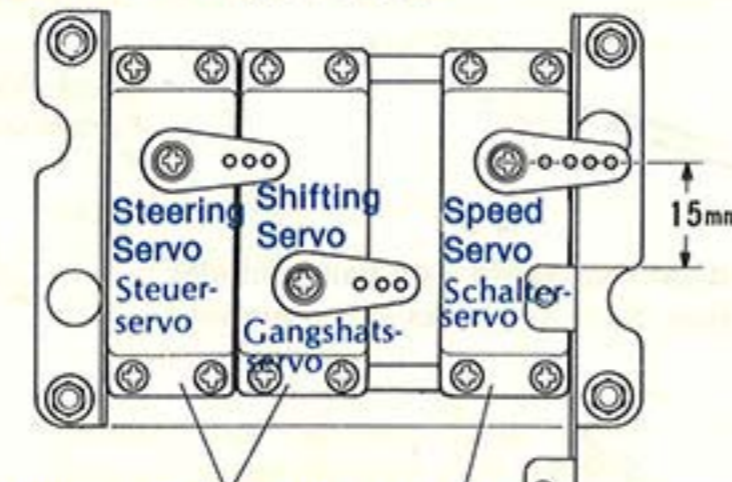

Clockwise Servo Drehung nach rechts  
Reverse Servo Drehung nach links

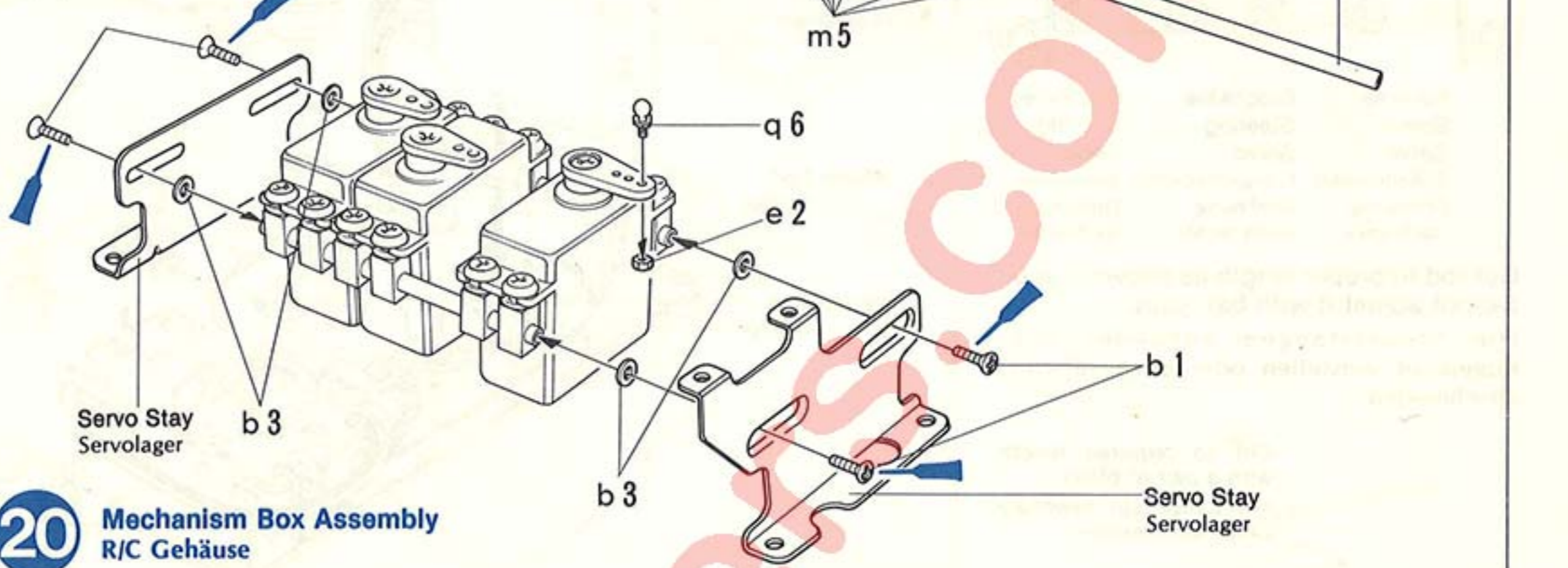

20 Mechanism Box Assembly  
R/C Gehäuse

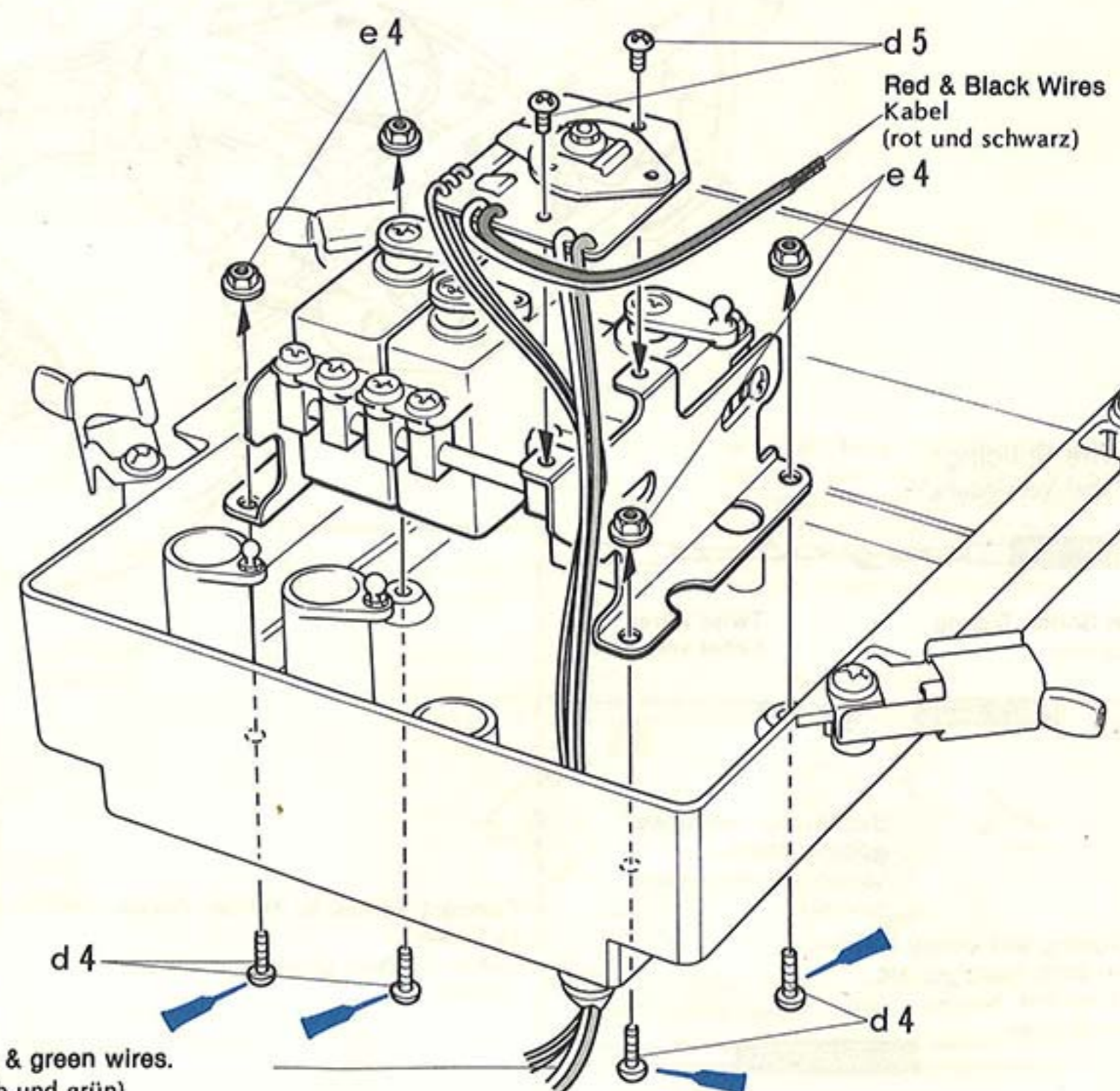
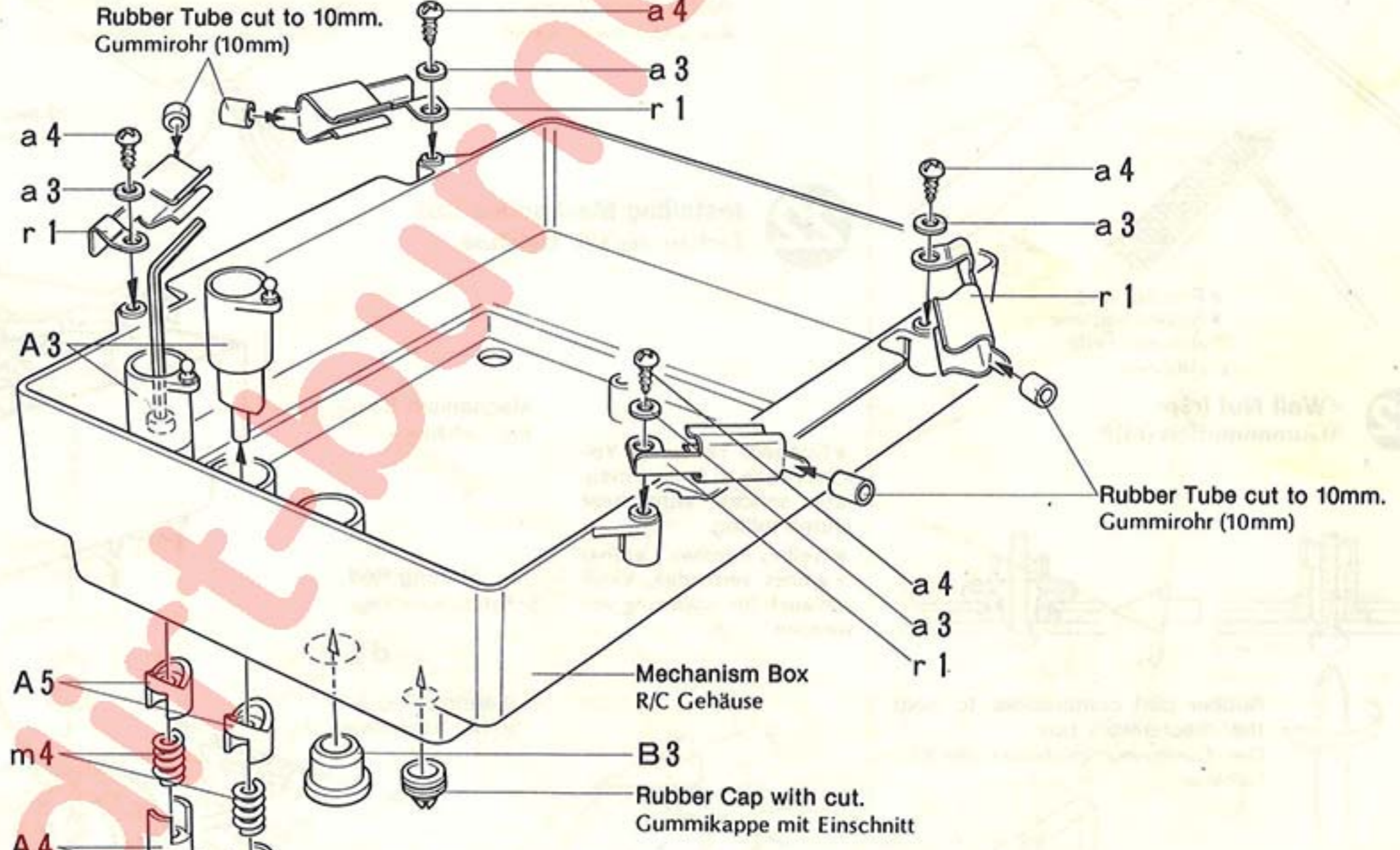

★ Feed out connector wire, yellow & green wires.  
★ Anschlusskabel herausführen (gelb und grün)

**21** «Attaching Crank Rods»  
«Einbau der Kurbel-Schubstangen»

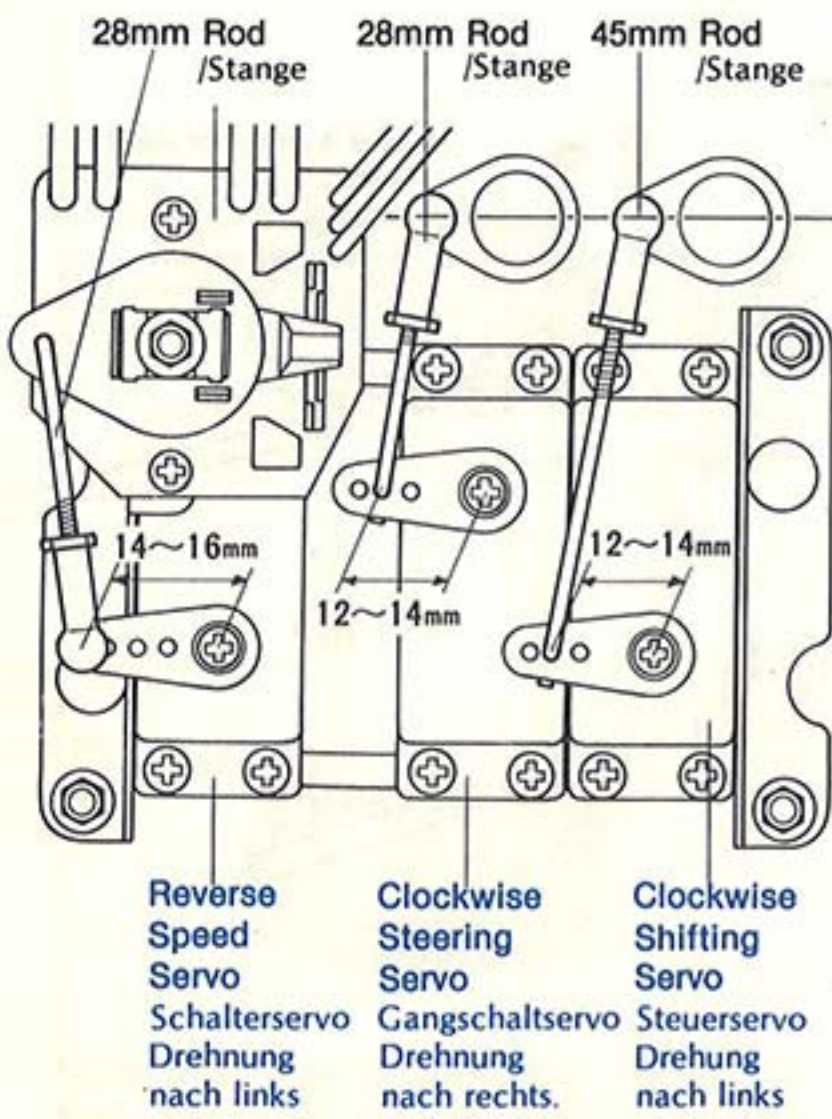

Cut rod to proper length as shown if you cannot adjust it with ball joint.  
Die Steuerstangen entweder mit Kugelkopf einstellen oder entsprechend abschneiden.

Cut to required length with a pair of pliers.  
Mit Zange auf benötigte Länge abschneiden.

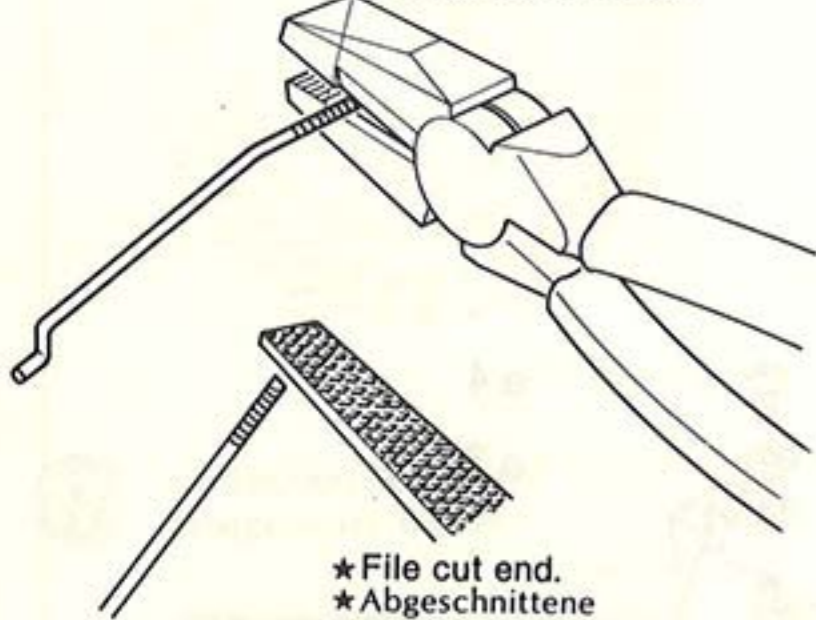

**22** «Well Nut (r3)»  
«Gummimuffen (r3)»

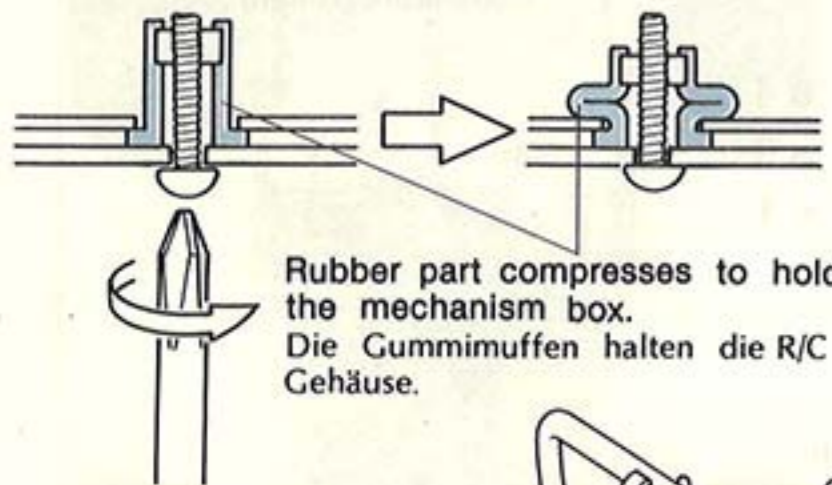

«Wire Splicing»  
«Kabel Verwindung»

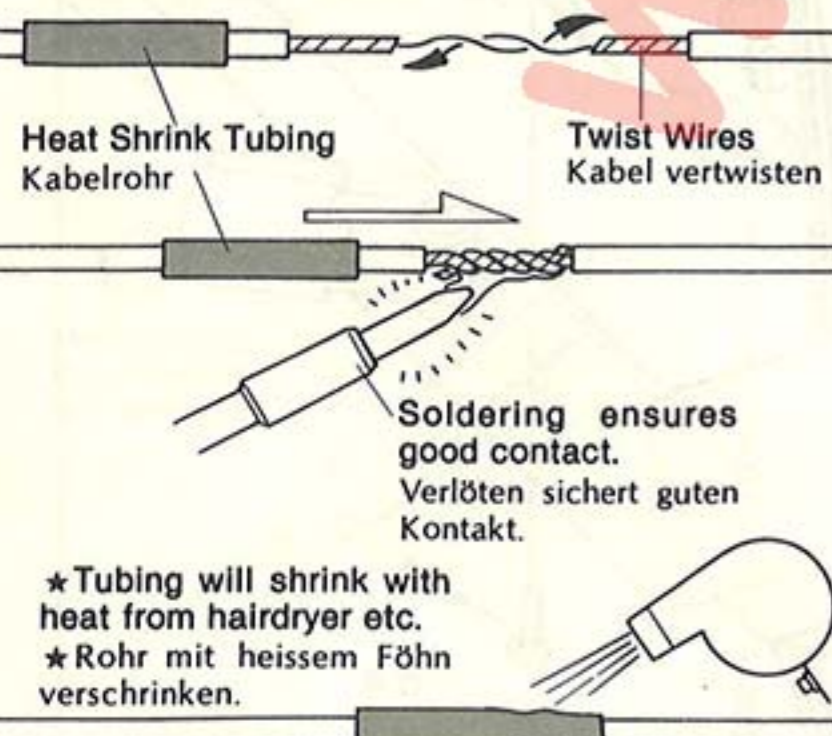

**21** Attaching Crank Rods  
Einbau der Kurbel-Schubstangen

\*Set servo arms in neutral position beforehand.

«45mm Rod» Make 1 set.  
«45 mm Rod» 1 Satz machen.

«28mm Rod» Make 2 sets.  
«28mm Stange» 2 Satz machen.

Crank Rod 45mm  
Kurbelstange 45mm

Crank Rod 28mm  
Kurbelstange 28mm

\*Adjust rod length with ball joint (q5).  
\*Länge durch Kugelkopf (q3) einstellen.

\*Adjust rod length with ball joint (q5).  
\*Länge durch Kugelkopf (q5) einstellen.

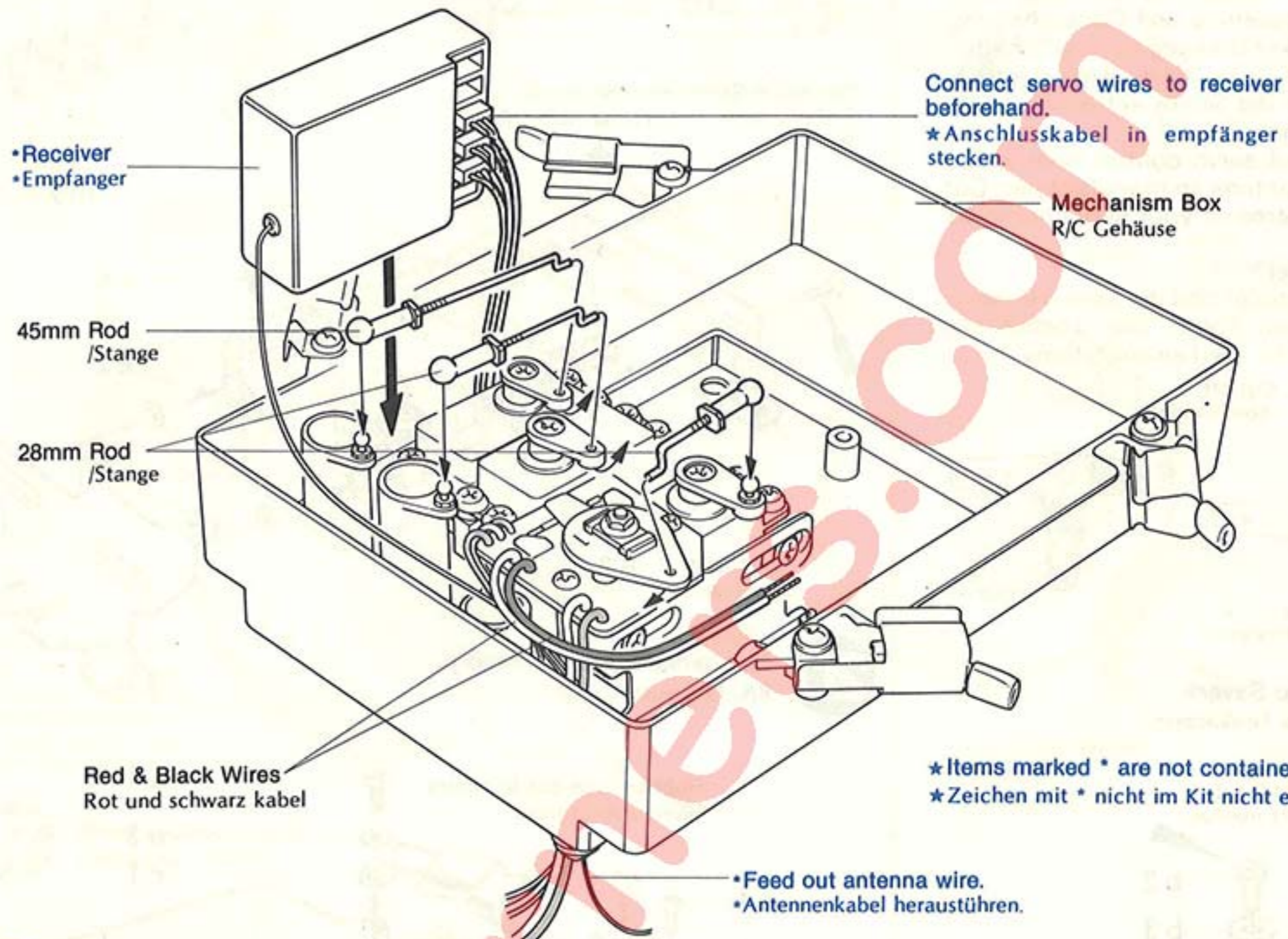

**22** Installing Mechanism Box  
Einbau der R/C Gehäuse

\*Connect Yellow to Yellow, Green to Green. Insulate splices with heat shrink tubing.  
\*Gelbes + gelbes, grünes + grünes verbinden. Vinylschlauch für Isolierung verwenden.

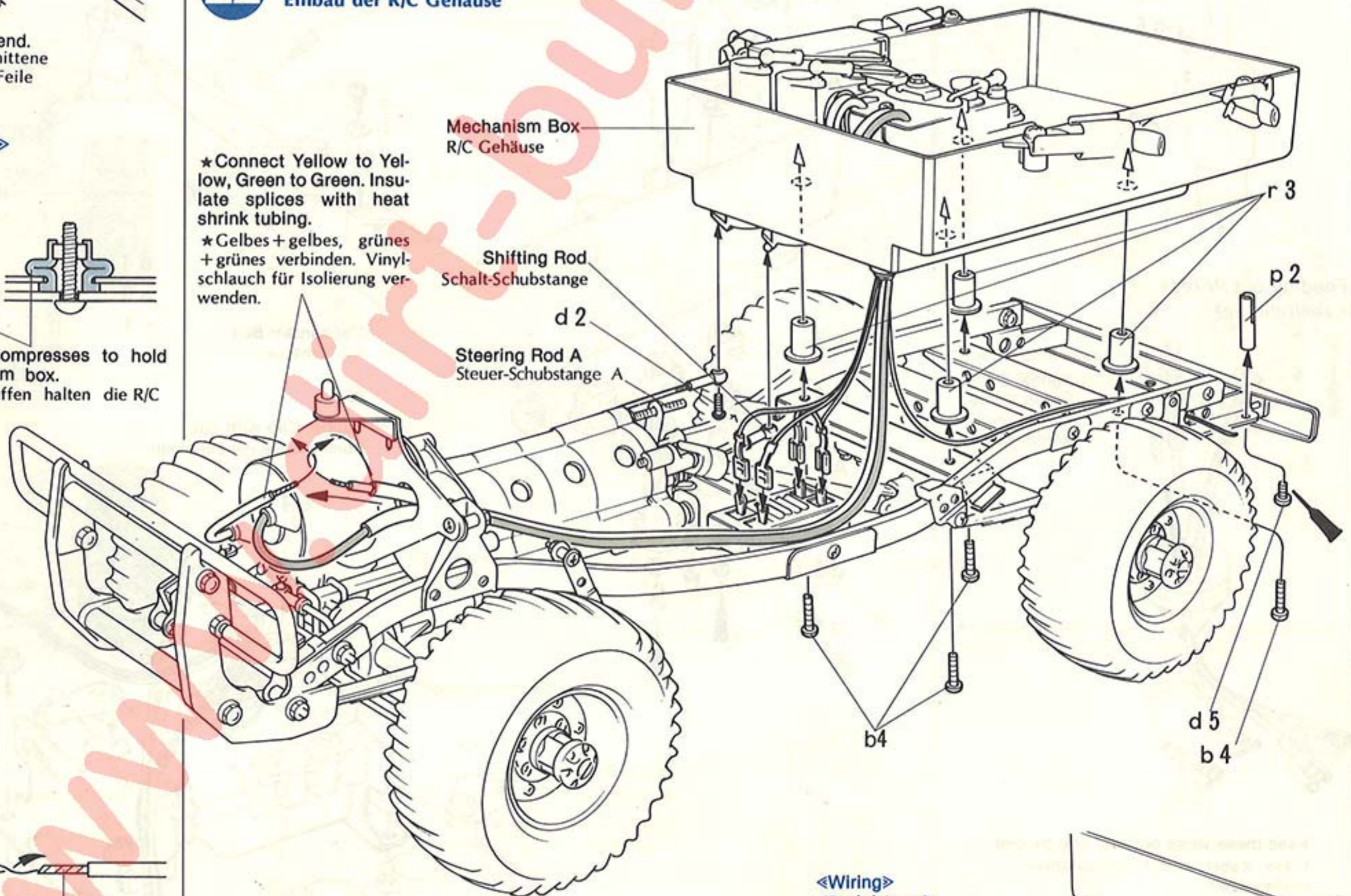

«Wiring»  
«Drahtleitung»

Connect Yellow to Yellow, Green to Green.  
Gelbes + gelbes, grünes + grünes verbinden.

Connector Wires (Blue)  
Anschlusskabel (blau)  
Connector Wires (Violet)  
Anschlusskabel (violett)

**23** «Transmitter Stick & Servos»  
«Sender Steuerhebel und Servos»

Connect receiver battery to receiver and check out servo movement by manipulating transmitter sticks.

Empfängerbatterie anschliessen und Servo-Drehmoment mit Sender Steuerhebel abstimmen.

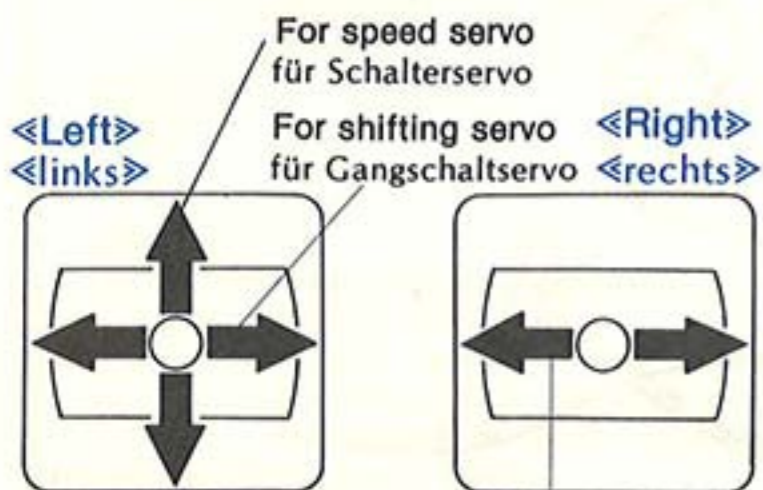

**24** «Attaching Mechanism Box Lid»  
«Mechanikbox-Deckel»

Mechanism Box Lid has front and rear. Snap projecting guides into servo saver holes when shutting the lid. After closing, fasten with clips r1. Be sure to secure the lid firmly before commencing gear shift adjustment.

Der Deckel hat Vorder- und Rückseite. Vorstehende Führung in die Löcher der Servo-Saver schnappen und dann Deckel schliessen, Clips r1 einschnappen. Den Deckel erst absichern und dann Gangwechseleinsteller anbringen.

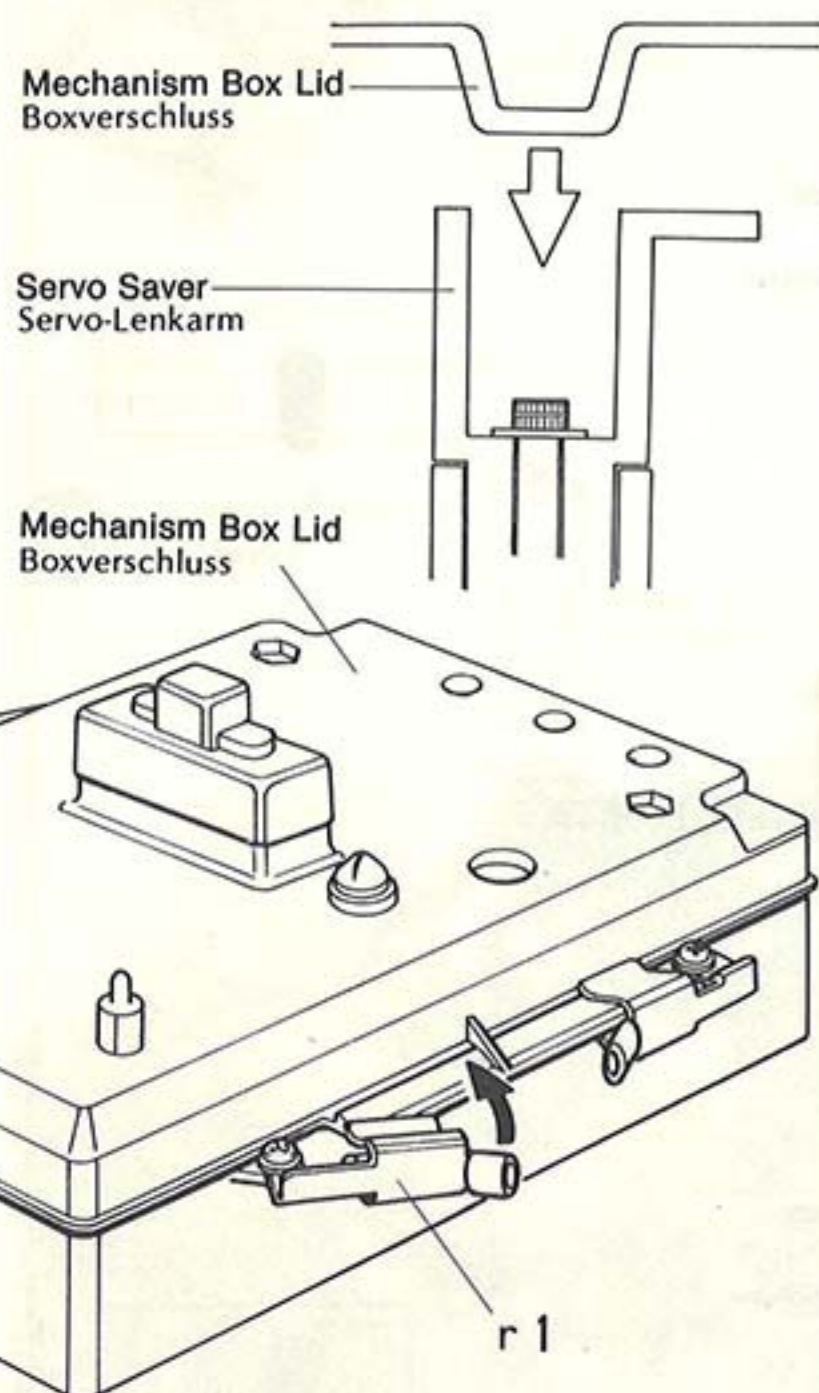

**25** «Servo Horn & Stroke»  
«Servo Horn und Ausschlag»

Movement of switch, steering or shift can be altered by changing hole position of servo horn. The closer to the axis the hole is, the smaller the movement becomes, and the farther from the axis, the longer the throw.

Schalter, Steuerung oder Schaltung kann verändert werden durch wechseln der Löcher im Servohorn.

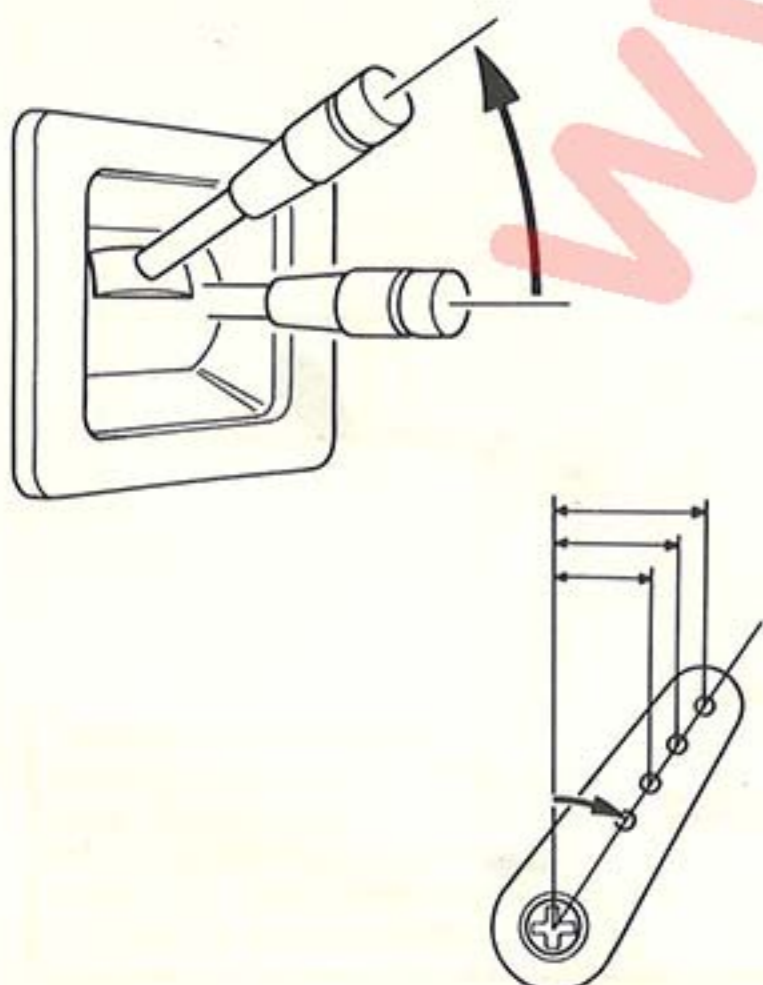

**23** Installing Tamiya Ni-Cd 6V-4000mAh Battery  
Einbau des Tamiya NC 6V-4000mAh Akkus

\*If you are going to install 6V-1200mAh or 7.2V-1200mAh battery on the vehicle, refer to page 15.  
\*Verwendung eines 6V-1200mAh NC Akku's siehe Seite 15.

•Battery Set Connector  
•Akku-Kupplung

Connect Red to Red, Black to Black. Insulate splices with heat shrink tubing.  
Rot + rot, schwarz + schwarz verbinden. Vinylschlauch für Isolierung verwenden.

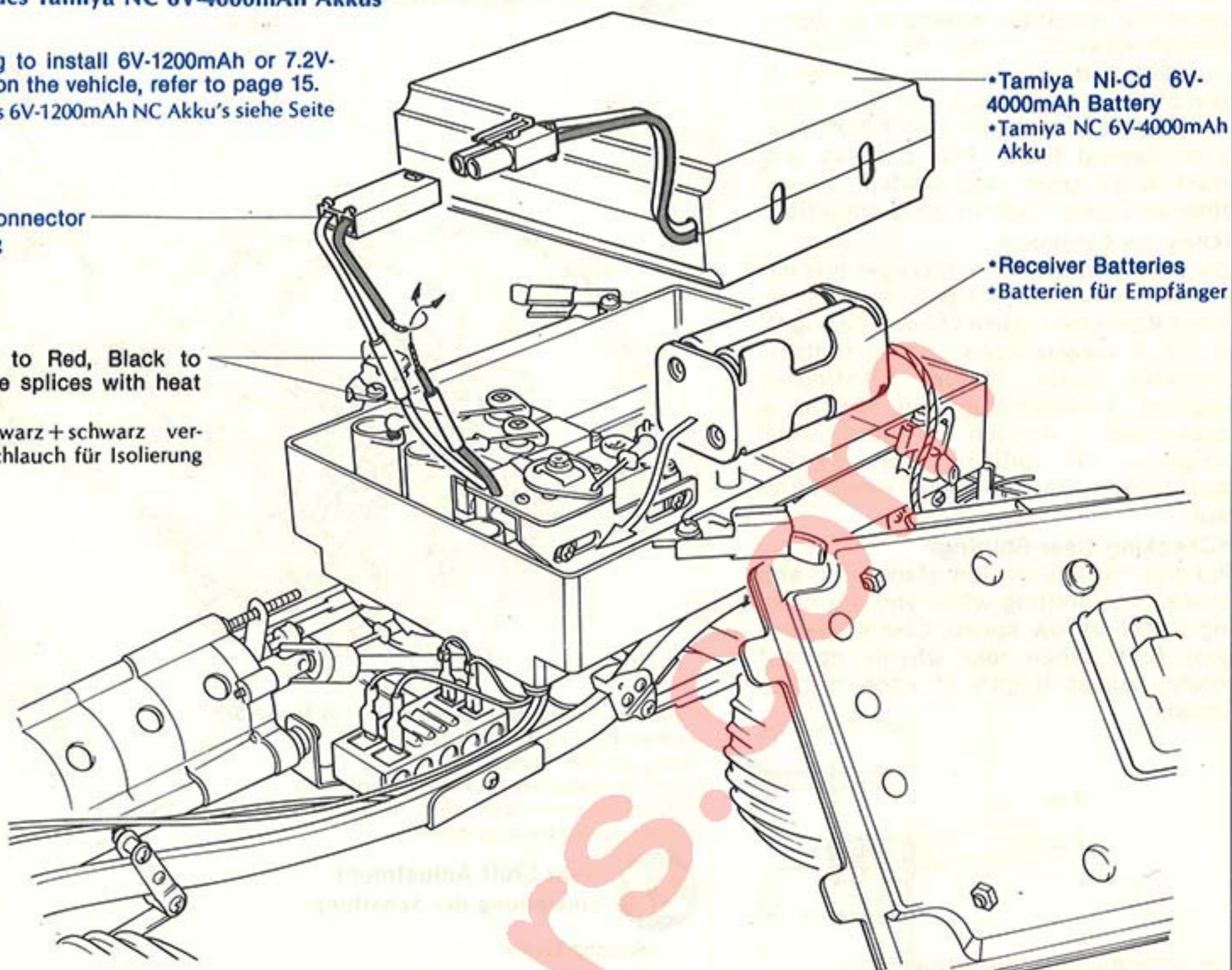

**24** Attaching Mechanism Box Lid  
Einbau des Boxverschlusses

Mechanism Box Lid Boxverschluss

Mechanism Box R/C Gehäuse

Antenna Mast Antennenrohr

•Receiver antenna slides up inside mast.  
•Kabel durch Antennenrohr schieben.

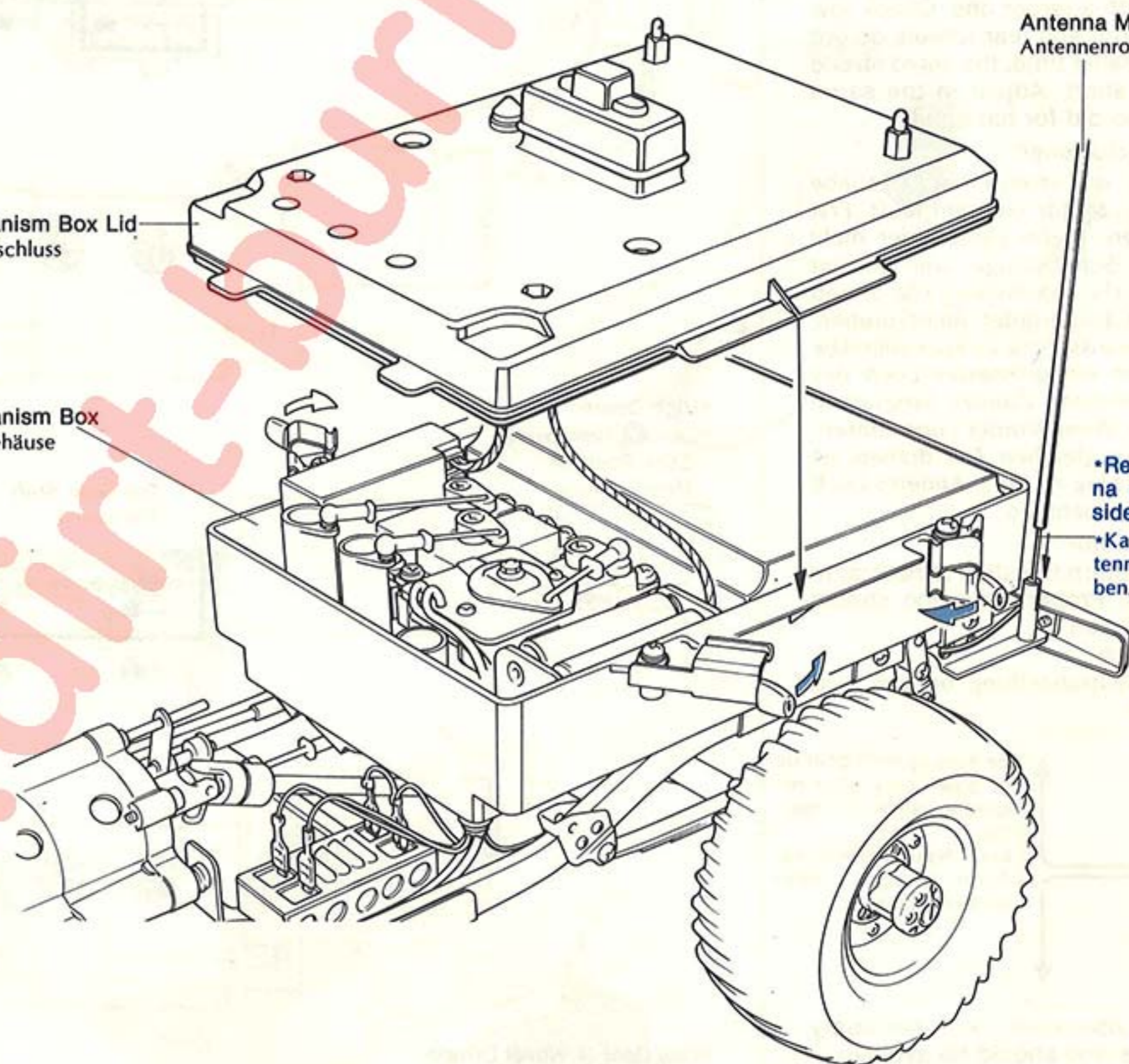

**25** Throttle Adjustment  
Einstellen des Schalterservos

«Transmitter Left Stick»  
«Sender-Linkshebel»

Full Power  
Volle Kraft

Stop  
Stopp

Full Reverse  
Volle Kraft-rückwärts

Top Second Low Stop  
Topspeed 2.Gang Langsam Stopp

\*Adjust hole position of servo horn so that switch blade moves to the place shown when transmitter stick is pushed up to full.  
\*Wenn Hebel ganz oben muss Servo auf Top speed vorwärts stehen.

\*Hole position of servo horn decides switch stroke.  
\*Die Geschwindigkeit richtet sich je nach Wahl des Loches auf dem Servohorn.

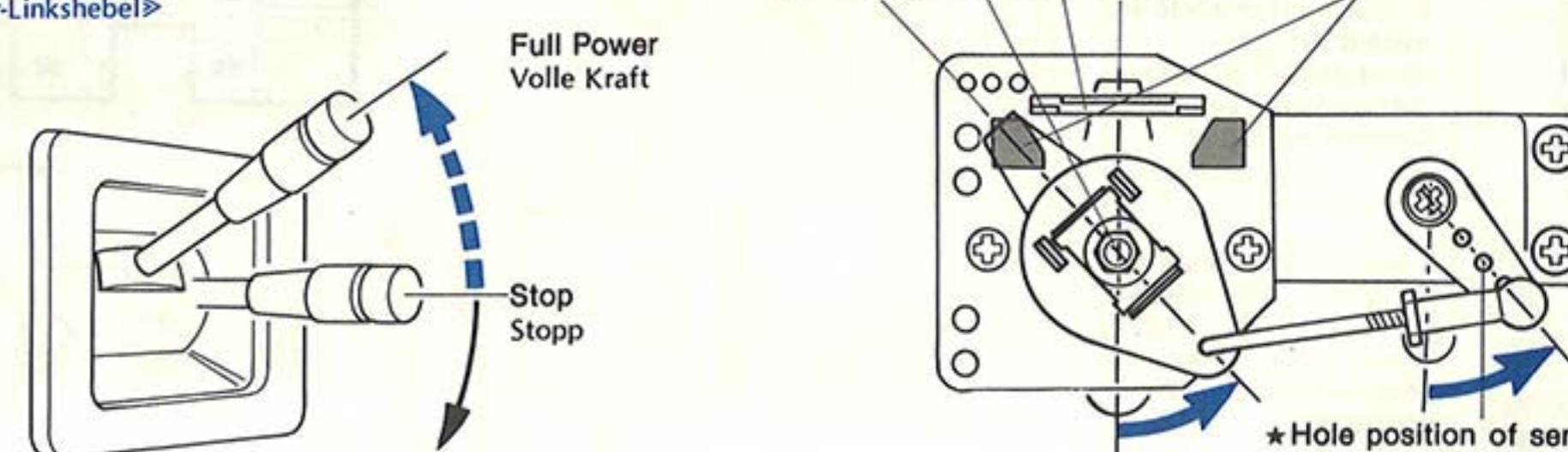

**«Lubricating Gear Box»**

Before running the car, be sure to lubricate gear box. Put the chassis on a stand, etc. to get the wheels in air. Apply enough spray oil through the three holes provided, and run gears for 5 minutes at low, 5 minutes at middle and 10 minutes at top speed. During this operation, apply oil several times. This process is a must to get gears well seated to each other and keep them in good condition.

**«Ölen des Getriebes»**

Vor Laufenlassen des Fahrzeuges erst das Getriebe ölen. Das Chassis hochstellen, damit Räder frei drehen können. Genug Öl in die 3 vorgesehenen Löcher sprühen, Getriebe laufen lassen. 5 Minuten langsam, 5 Minuten mittlere Geschwindigkeit und 10 Minuten Top-Speed. Dabei einigemal Öl sprühen. Dies ist ein muss! damit das Getriebe einwandfrei läuft.

**«Checking Gear Shifting»**

Put the chassis on the stand, etc. and check gear shifting while you are running motor at low speed. Check second gear first. When rear wheels do not rotate, adjust length of each rod as shown.

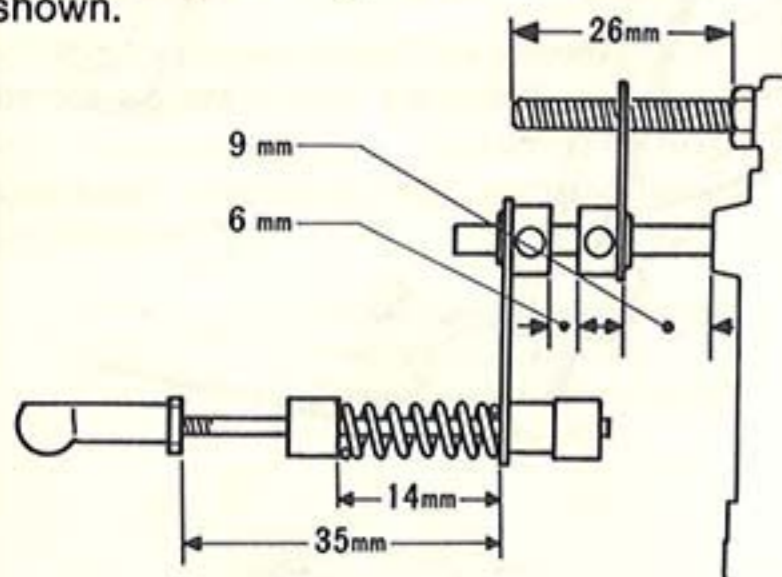

Next, check for high gear. If rear wheels do not rotate, the servo stroke must be too short. Move to outer hole or replace servo horn with a larger one. Check low gear last. If front and rear wheels do not rotate at the same time, the servo stroke must be too short. Adjust in the same manner as you did for high gear.

**«Prüfen der Schaltung»**

Chassis hoch und freistellen. Getriebe schalten, wenn Motor langsam läuft. Erst 2. Gang prüfen. Wenn Hinterräder nicht drehen, jede Schubstange wie gezeigt verlängern. Als nächstes Top-Speed prüfen. Wenn Hinterräder nicht drehen, muss der Servoausschlag zu kurz sein. Die Schubstange in ein grösseres Loch des Servohorns stecken. Zuletzt langsamen Gang checken. Wenn Vorder- und Hinterräder nicht zur gleichen Zeit drehen, ist der Servoausschlag zu kurz. Anderes Loch für Schubstange nehmen.

**«Stick Operation»**

★ Be sure to return the stick to neutral to change gears. Proper operation should be done as shown.

**«Hebelstellung»**

★ Hebel in Neutralstellung bringen und dann schalten.

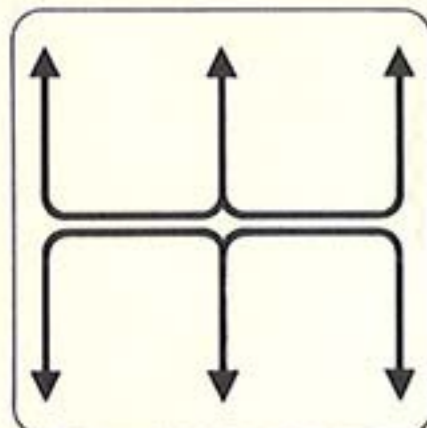

Be sure to shift gear up or down only after returning stick to neutral. Erst Neutralstellung, dann rauf oder runterschalten.

★ Following operation will seriously damage gears and should be avoided. ★ Folgendes beschädigt Getriebe und sollte vermieden werden.

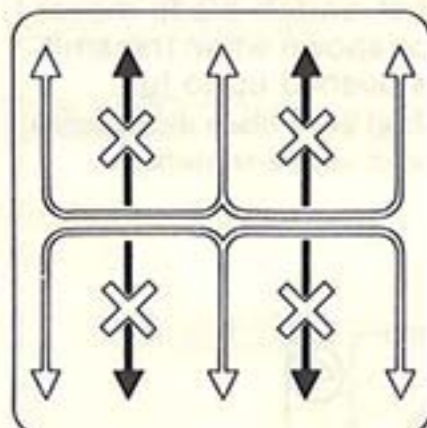

If shifting stick is moved left or right less than full throw, and then moved up or down, gears can be damaged. Follow path of white arrows only! Wenn Hebel zu wenig auf Top-Speed geht, wird Getriebe beschädigt.

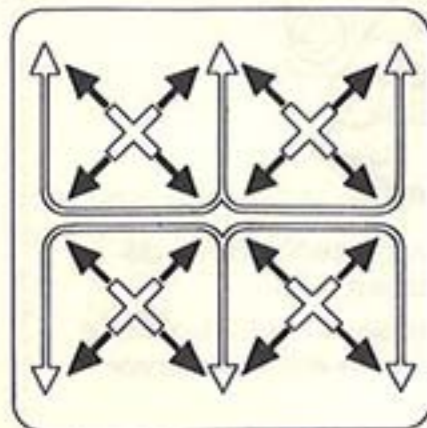

If stick moves diagonally, gears are loaded down. Wenn Hebel diagonal geht, werden die Gänge überlastet.

**26 Lubricating Gear Box  
Ölen des Getriebes**

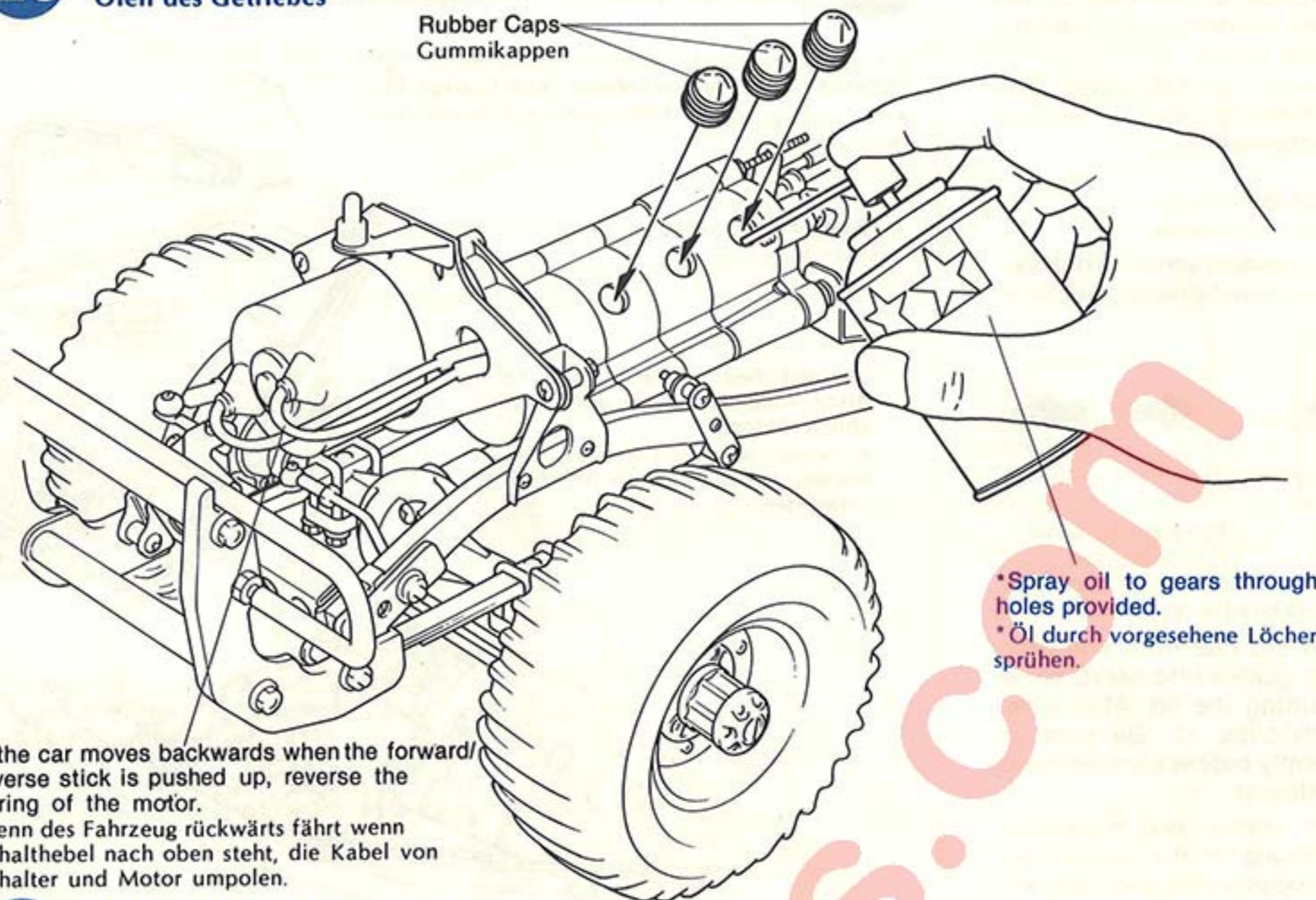

If the car moves backwards when the forward/reverse stick is pushed up, reverse the wiring of the motor. Wenn des Fahrzeug rückwärts fährt wenn Schalthebel nach oben steht, die Kabel von Schalter und Motor umpolen.

**27 Gear Shift Adjustment  
Einstellung der Schaltung**

«Second Gear»  
«2. Gang»  
Stick Position  
Hebelstellung



Second Gear Shift  
2. Gang

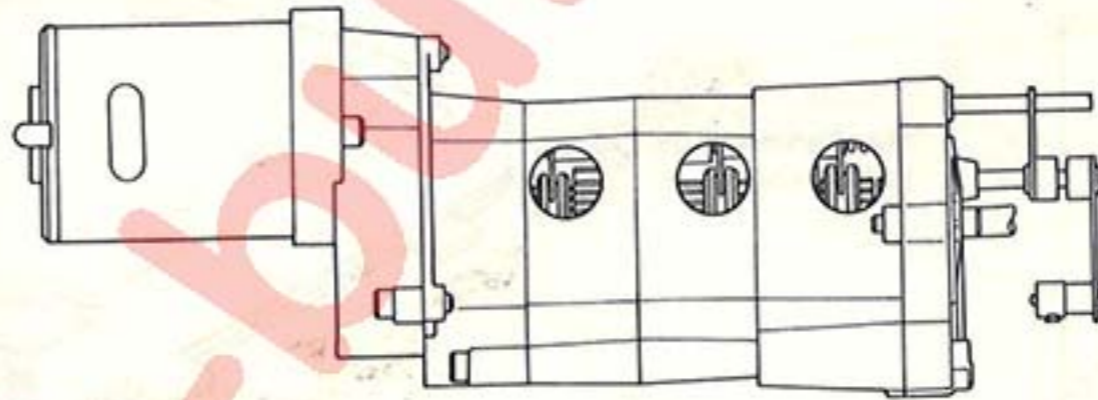

«High Gear»  
«Grosse Übersetzung»  
Stick Position  
Hebelstellung



Top Gear Shift  
Top-Speed

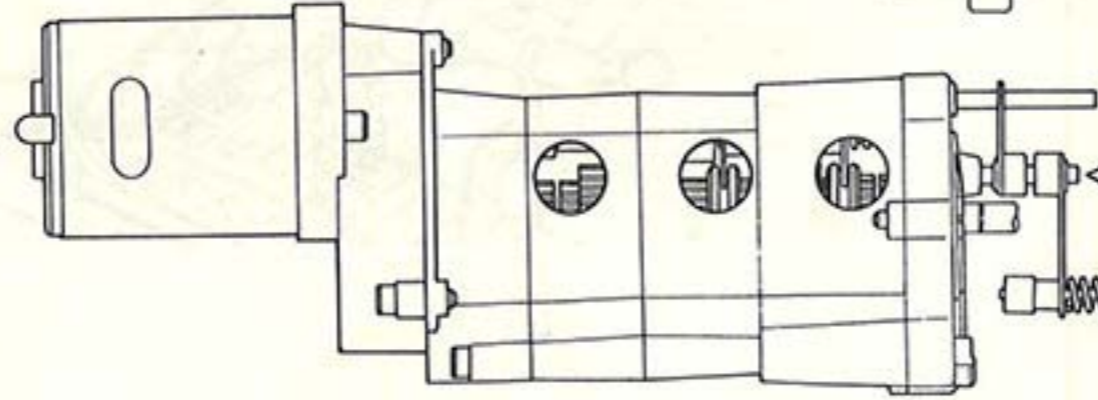
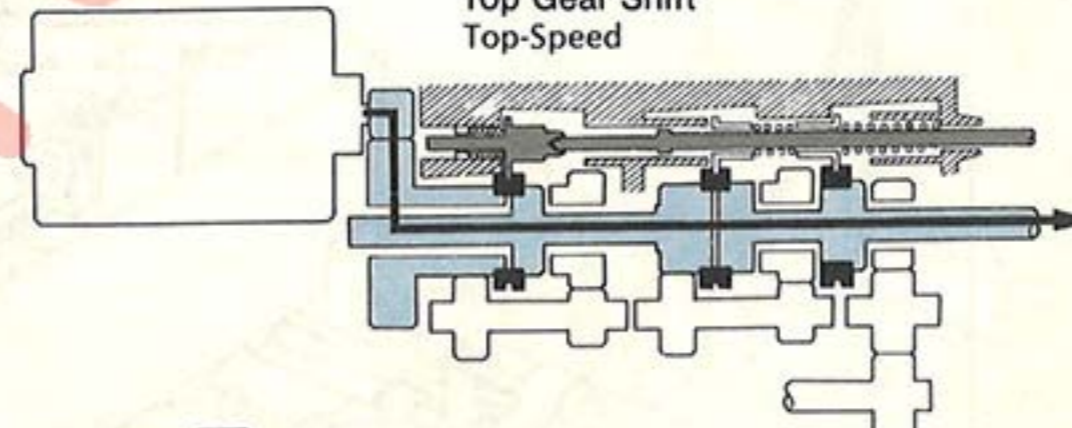

«Low Gear (4 Wheel Drive)»  
«langsam (4 Rad)»  
Stick Position  
Hebelstellung



Low Gear Shift  
langsam

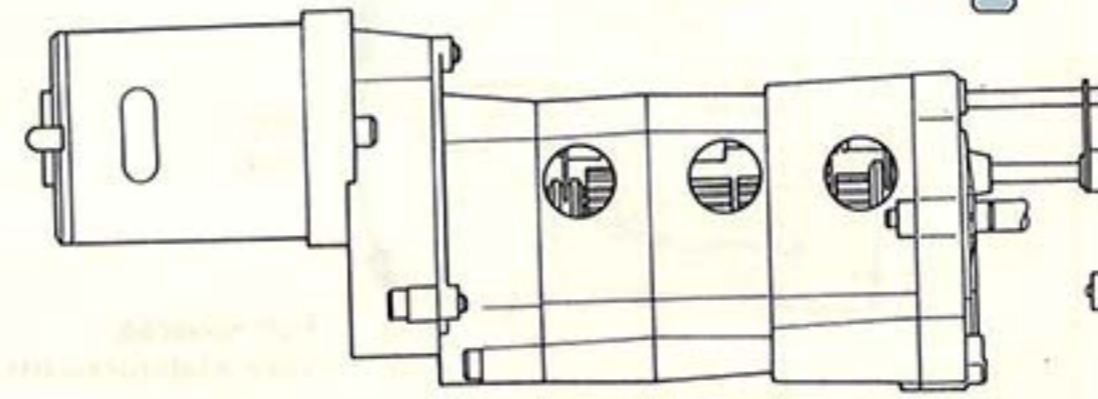
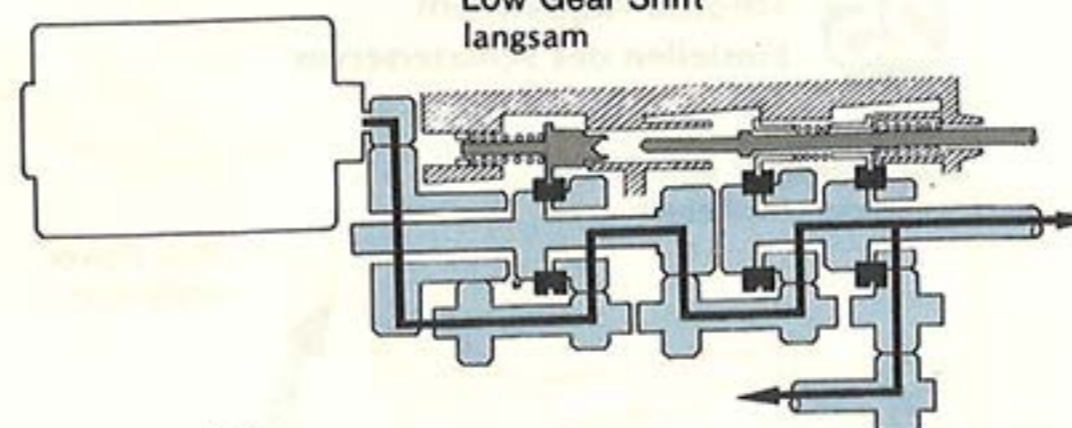

**28** <<Attaching Radiator Grill>>  
<<So Kühlergrill einbauen>>

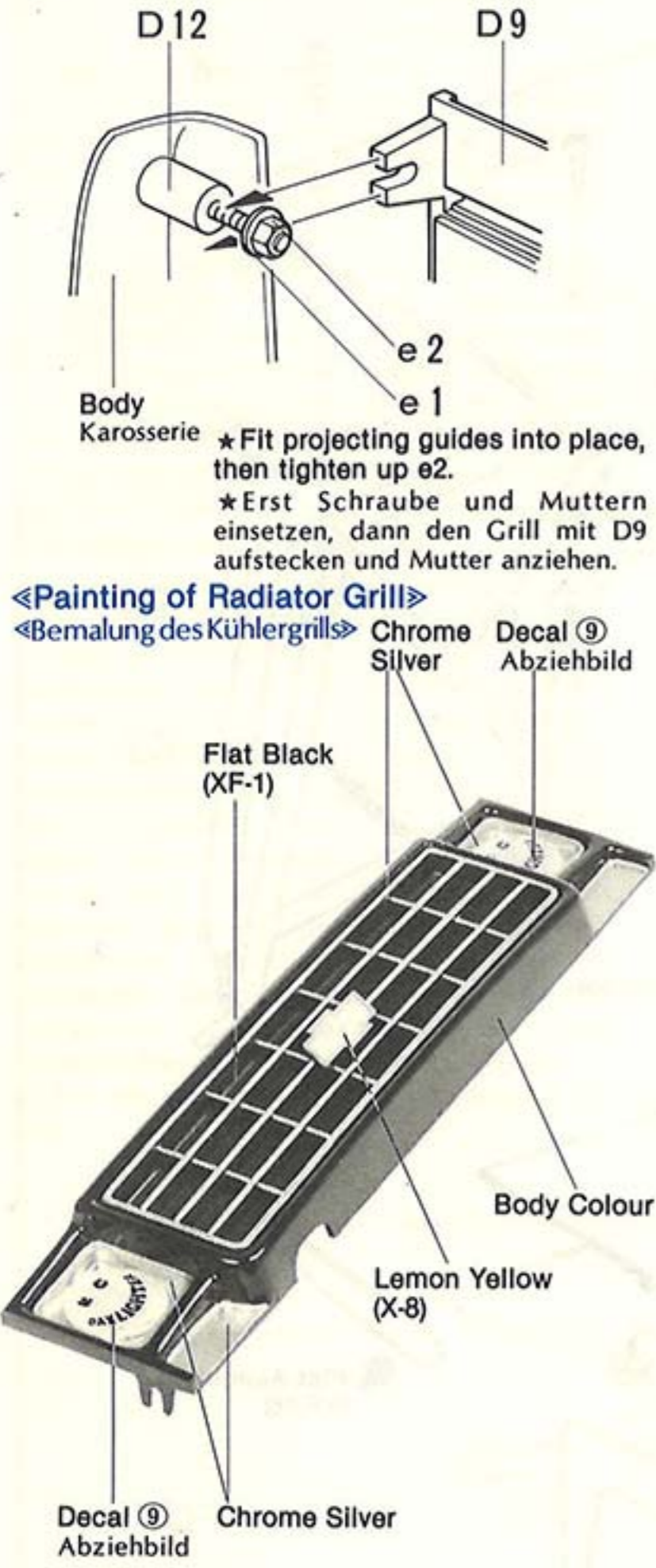

**30** <<Driver Figure>>  
<<Fahrer>>

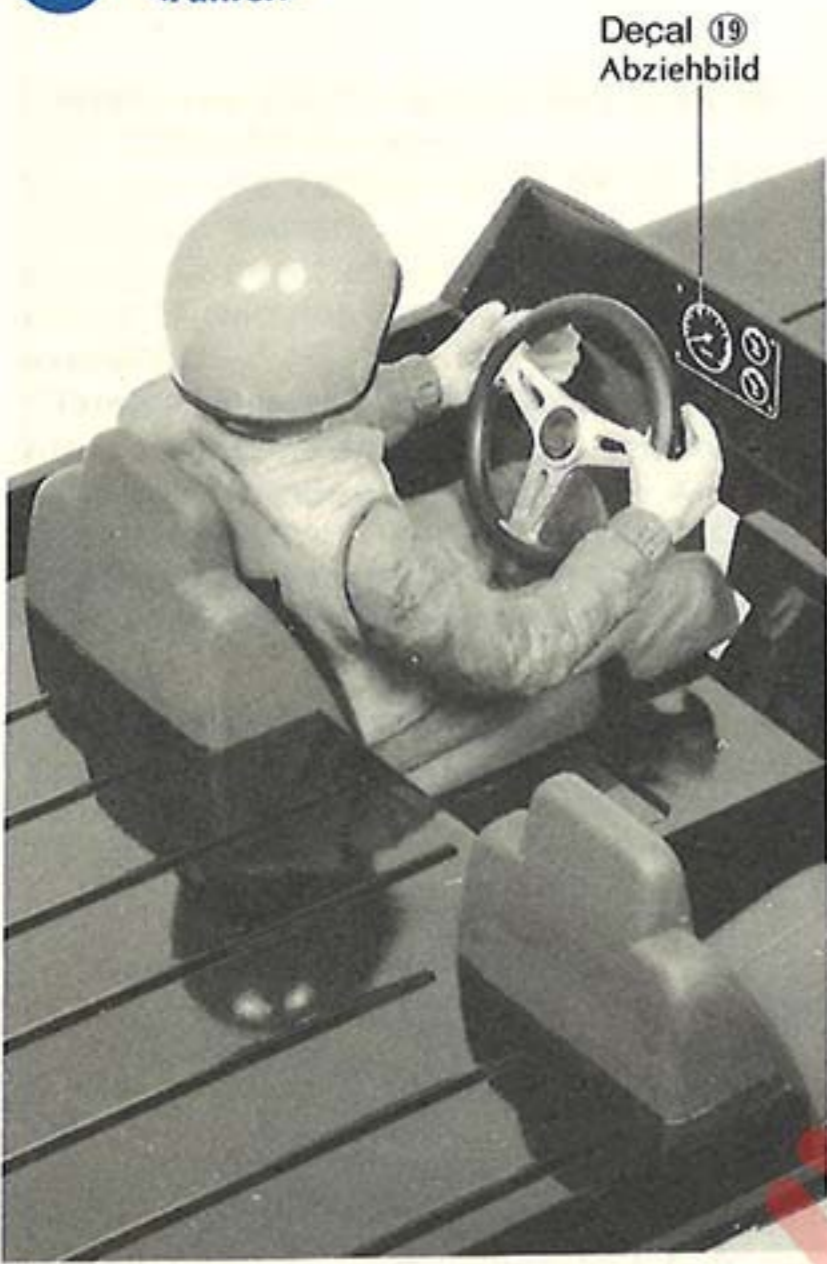

**Tamiya Acrylic Paints**  
Need precise colour matching? Try the new Tamiya acrylic paints. Engineered by modelers for modelers' use. The final cover for the finest models. Insist on Tamiya for perfect results.

**28** Attaching Radiator Grill  
Einbau der Kühlergrill

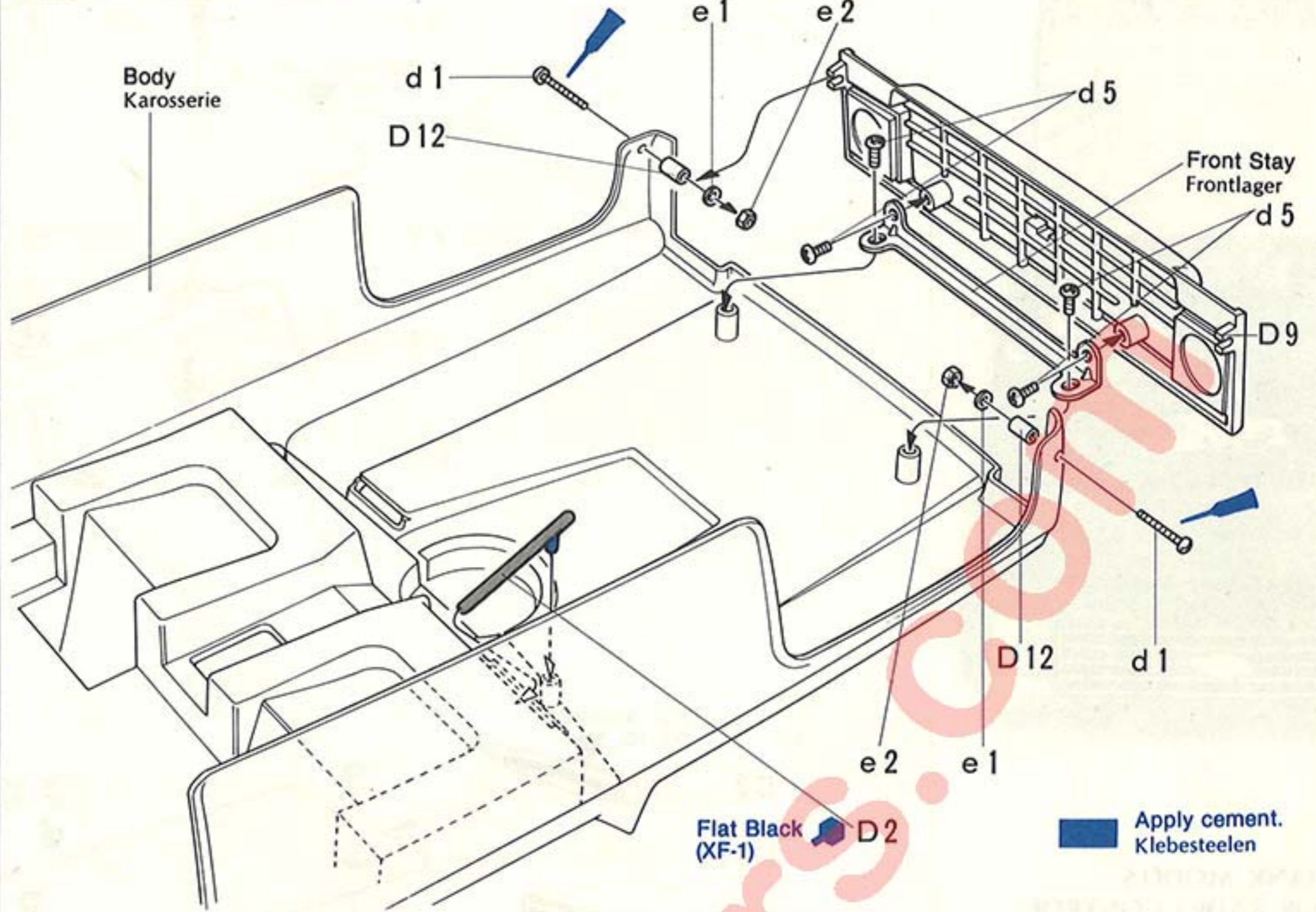

**29** Driver Figure  
Fahrer

Paint driver as you like.  
Fahrer je nach Wunsch bemalen.

\*Firmly cement head and arms into place.  
\*Arme und Kopf des Fahrers gut ankleben.

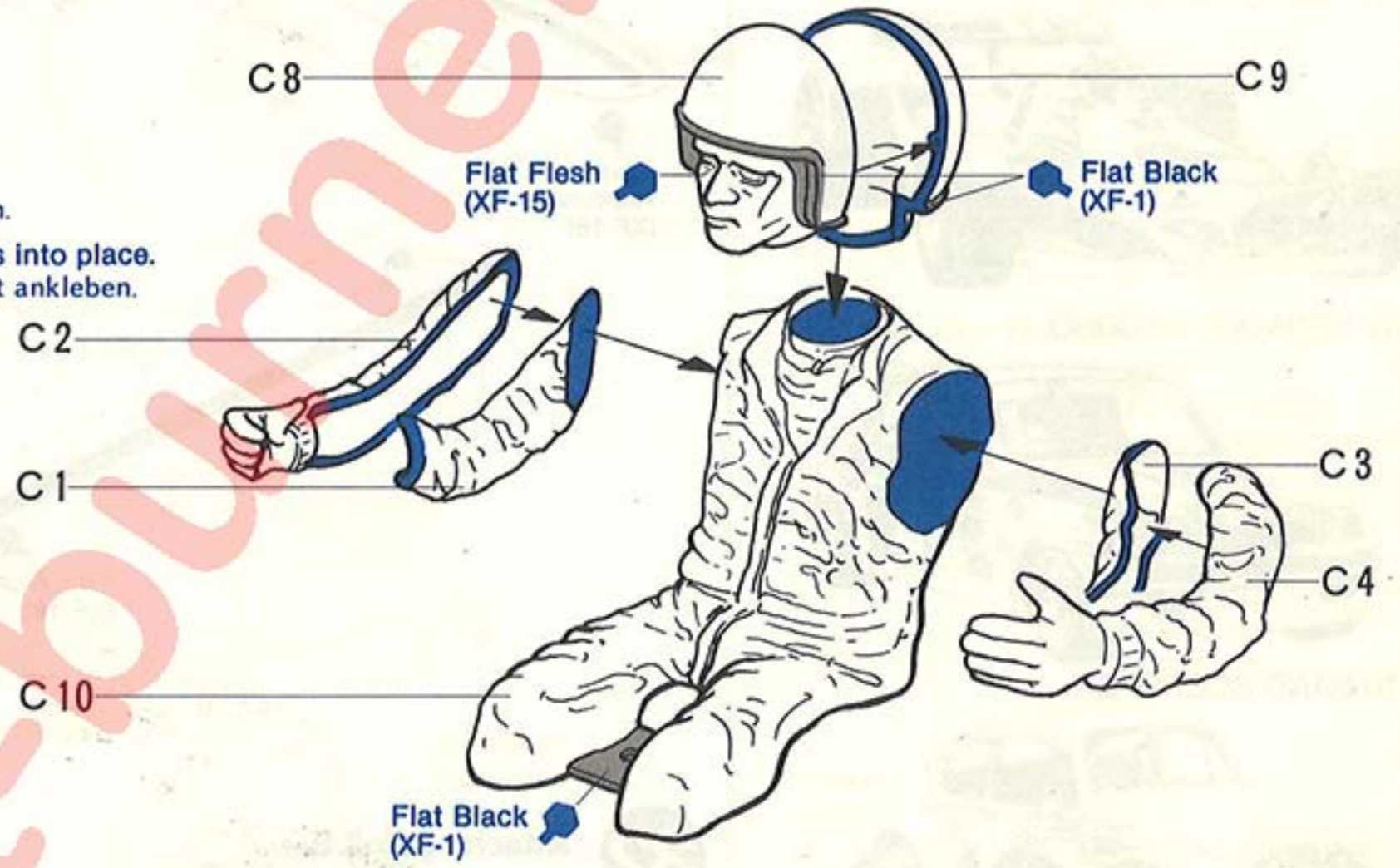

**30** Attaching Driver Figure  
Einbau des Fahrers

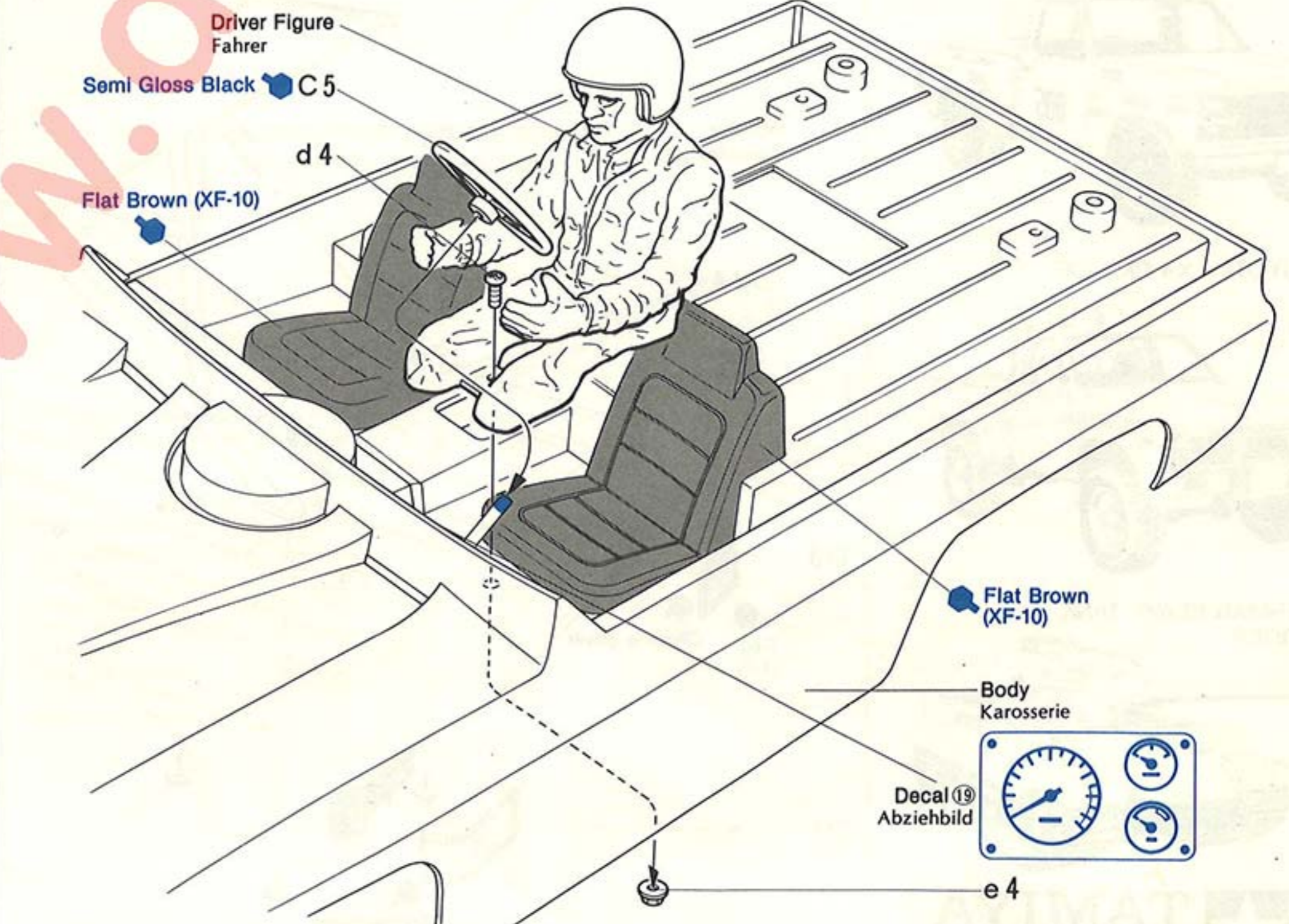

**32** «Completion of Body»  
«Karosserie – Endmontage»

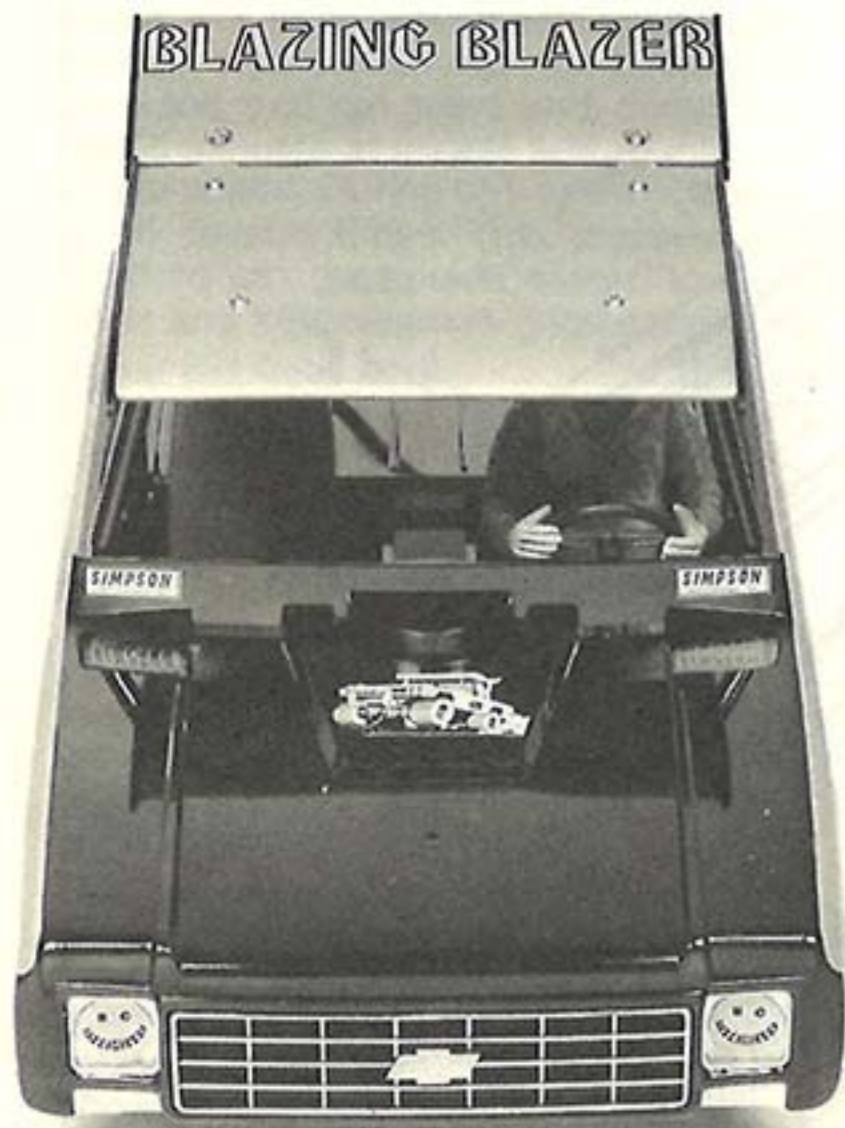

**CAR AND TANK MODELS  
SUITABLE FOR RADIO CONTROL**

1/10 WILLIAMS FW-07

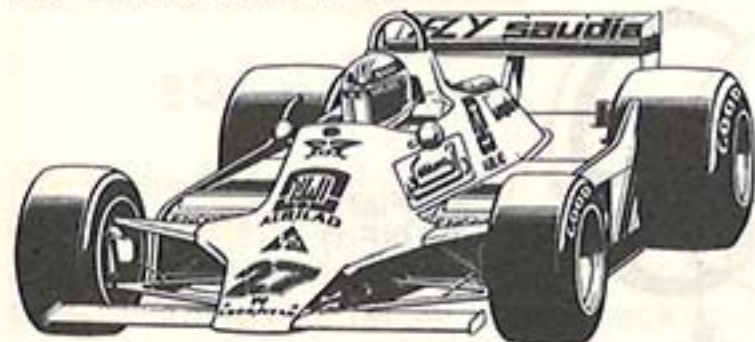

1/12 RENAULT 5 TURBO



1/10 SAND SCORCHER



1/10 FORD RANGER



1/10 TOYOTA 4x4 PICK-UP



1/16 GERMAN HEAVY TANK  
KING-TIGER

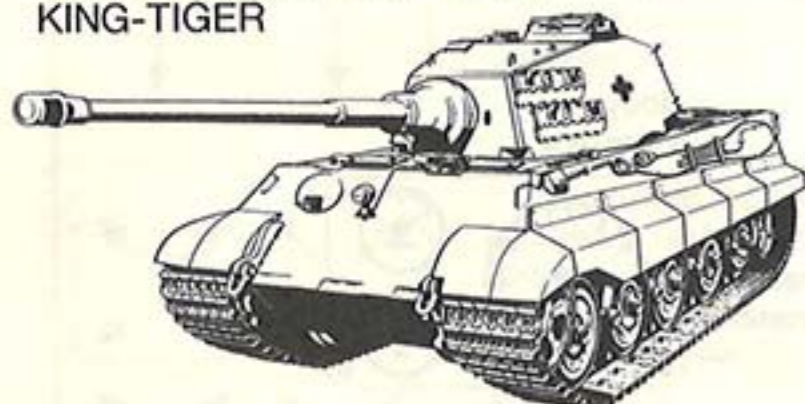

**31** Roll Bar Assembly  
Überrollbügel

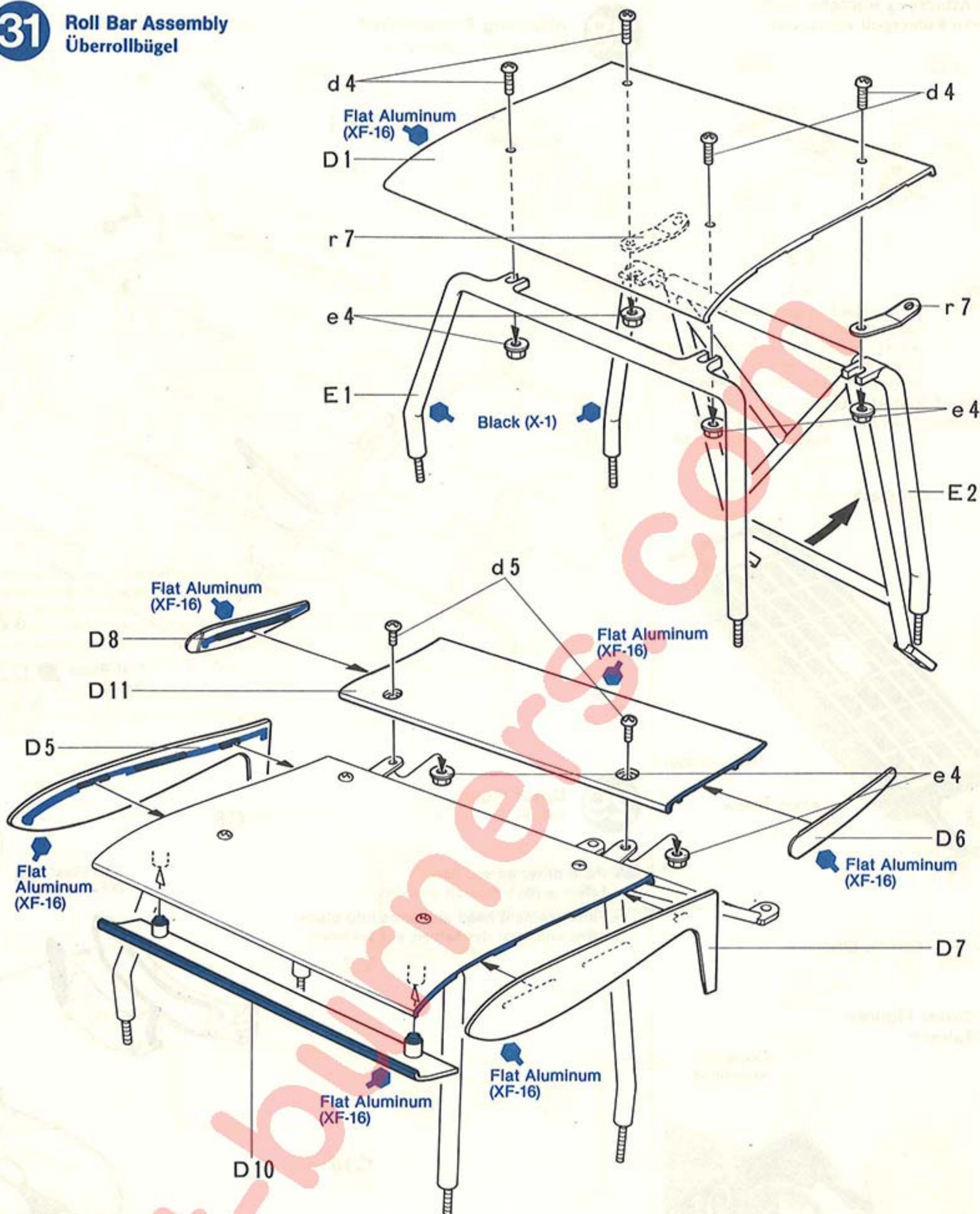

**32** Attaching Roll Bar  
Einbau der Überrollbügel

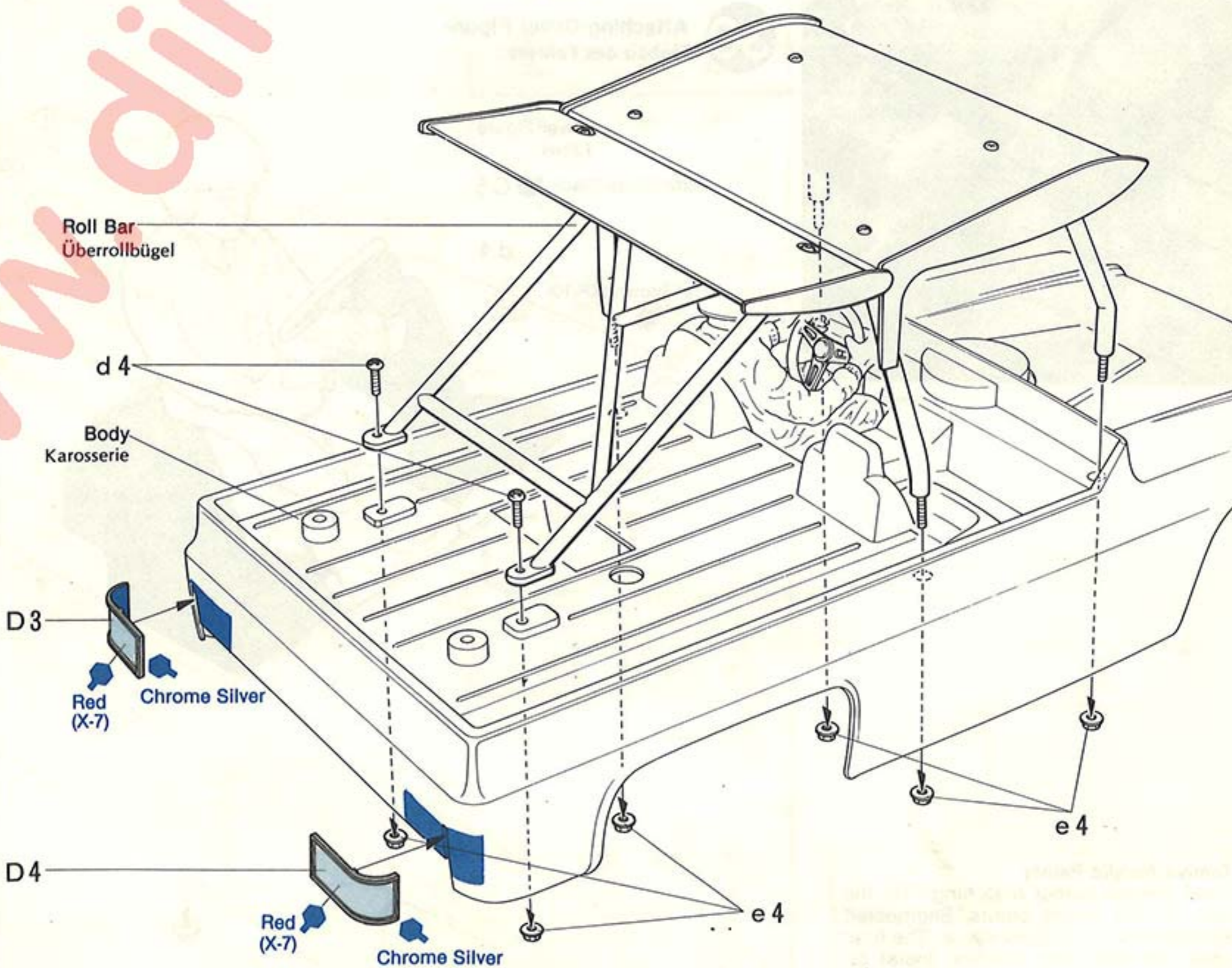

**1** <<Free Wheeling Hub>>  
<<Freilaufnabe>>

You can lock or un-lock the front wheels by just turning the hub caps 90°. Free wheeling hub is used to avoid mechanical loss by allowing the front wheels to rotate freely during 2 wheel driving, and it also allows improved cornering on flat road surfaces even while in 4 wheel drive.

Tamiya's free wheeling hub uses a one-way clutch, and the hubs are automatically locked when you shift down to low and drive forward. If the car was caught in muddy or bumpy place, get out of there by shifting down to low. When you are to drive the car in much worse conditions, you had better lock the wheel hubs beforehand.

Die Vorderräder können eingeschaltet oder gesperrt werden durch Drehen der Nabenkappen um 90 Grad. Durch die Freilaufnaben können die Vorderräder frei drehen bei Fahrt mit nur zwei angetriebenen Rädern und sie verbessern auch das Kurvenfahren auf flacher Ebene - sogar bei Allradantrieb. Tamiya's Freilaufnaben haben eine Einwegkupplung und die Naben sind automatisch gesperrt, wenn man auf langsam oder vorwärts schaltet. Wenn das Fahrzeug im Schlamm oder unebenen Gelände stecken bleibt, auf langsam herunterschalten und herausfahren. In schlechtem Gelände ist es besser, den Freilauf überhaupt zu sperren.

**33** Final Assembly  
Endmontage

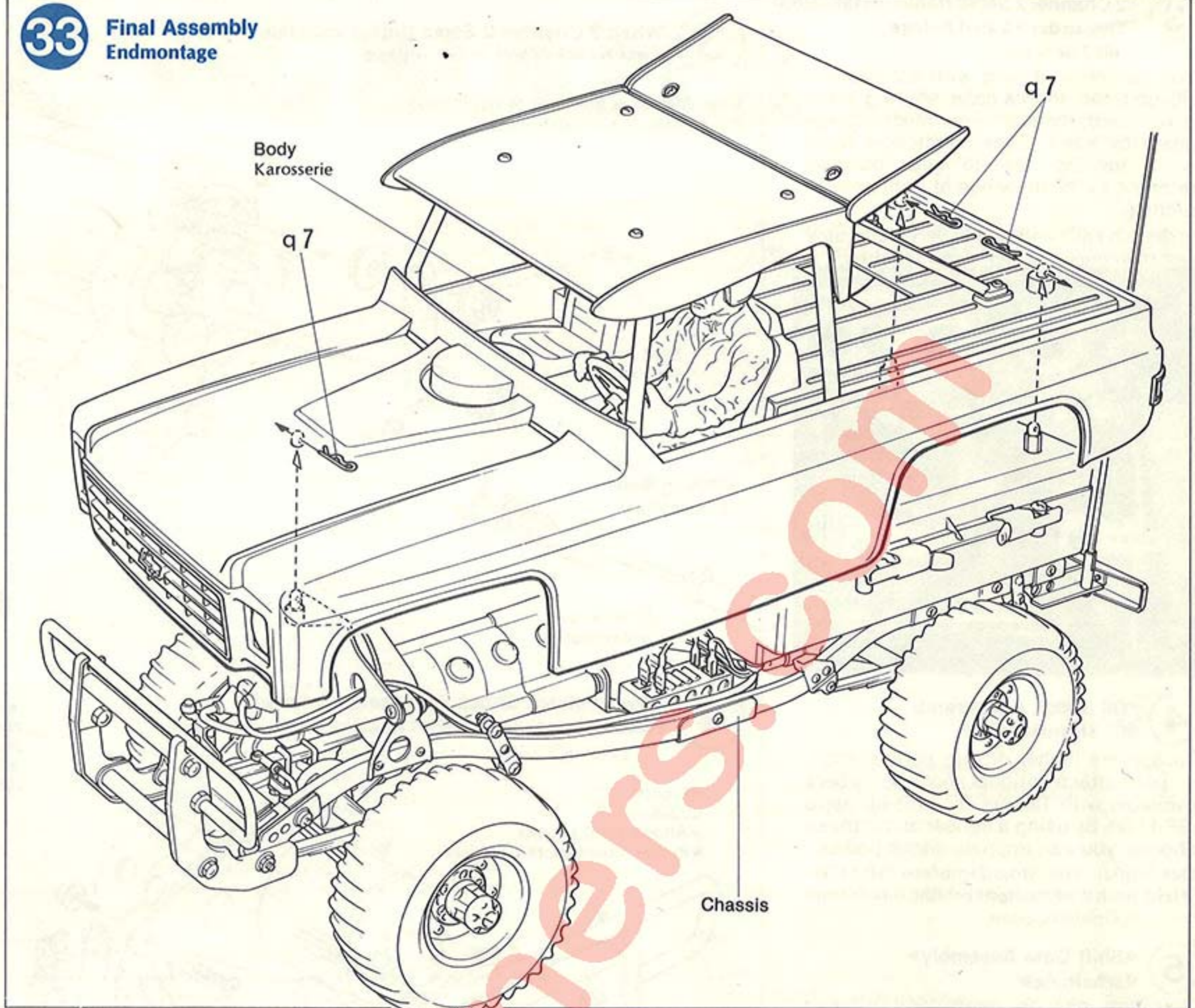

**1** How to lock Free Wheeling Hub  
Wie sperrt man die Freilaufnabe

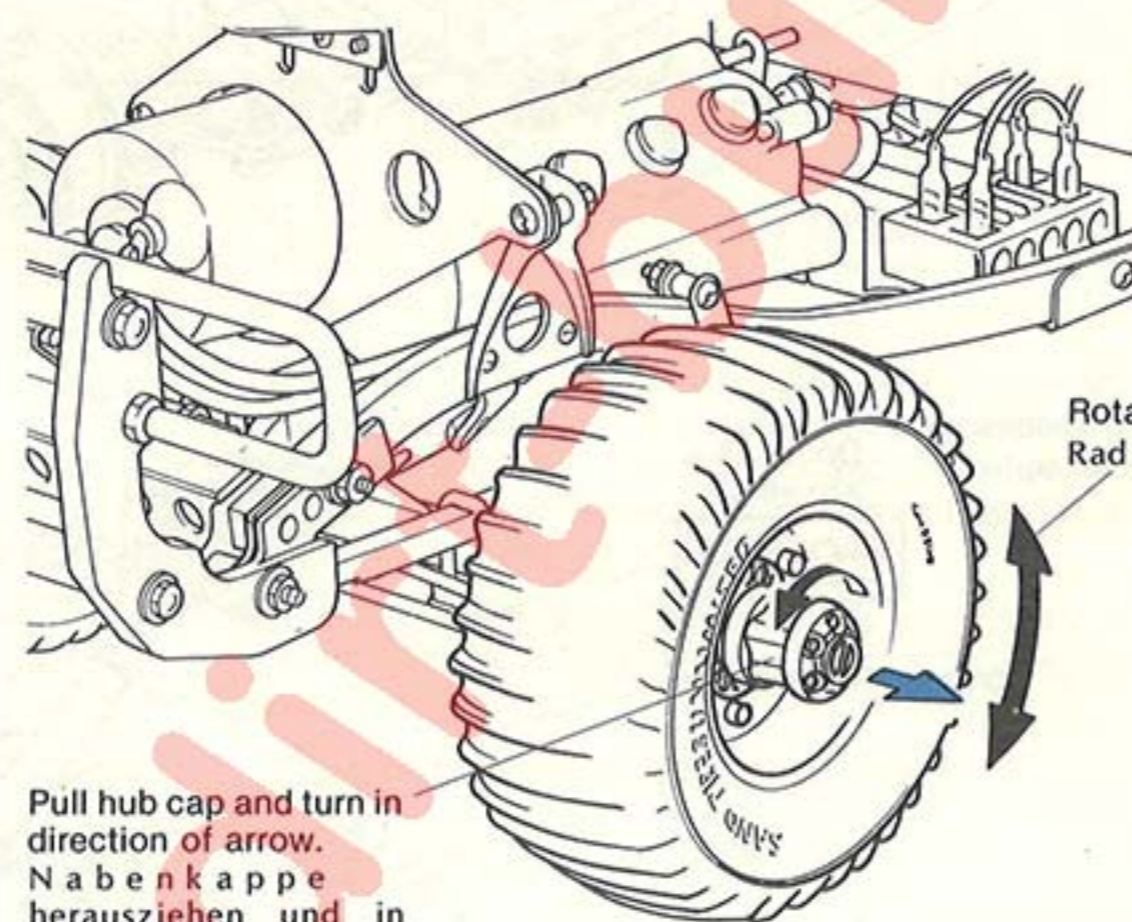

Pull hub cap and turn in direction of arrow.  
Nabenkappe herausziehen und in Pfeilrichtung drehen.

Unlocked (One Way Clutch)  
Nicht gesperrt - Einwegkupplung

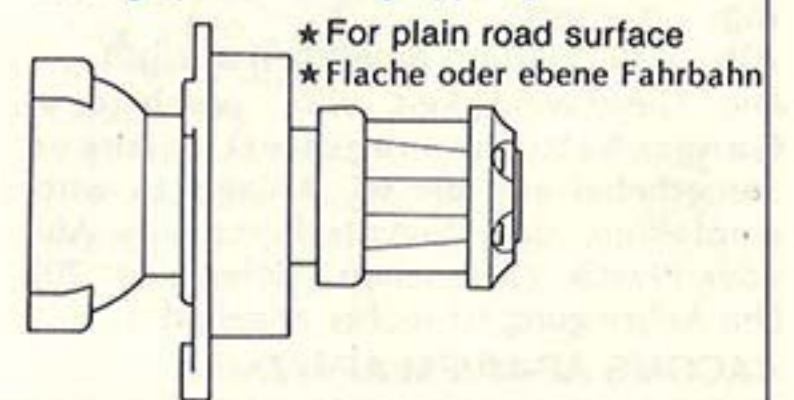

Locked  
gesperrt

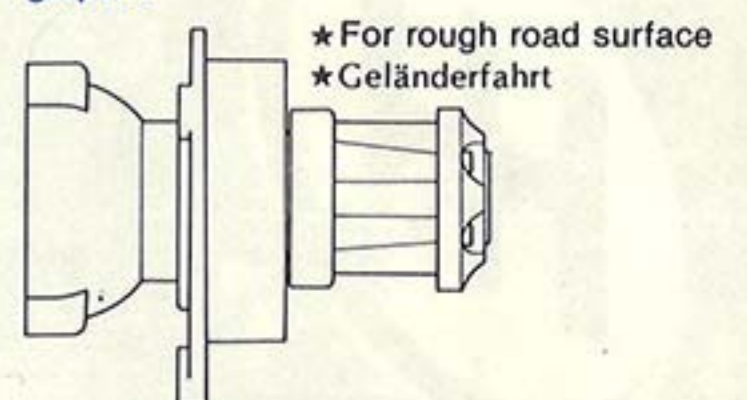

<<When you install Tamiya Ni-Cd 6V or 7.2V 1200mAh Battery>>

You can use Tamiya Ni-Cd 6V or 7.2V 1200mAh battery for driving power source. Connect wires as shown at right. About 8 minutes continued driving is available.

<<Tamiya 6V oder 7.2V 1200mAh Akku>>

Als Fahrakku können beide verwendet werden, es müssen dann aber die Kabel wie rechts gezeigt verbunden werden. Die Fahrdauer ist jedoch höchstens 8 Minuten, dann muss wieder aufgeladen werden.

Tamiya Ni-Cd 6V-1200mAh Battery  
Tamiya NC 6V-1200mAh Akku

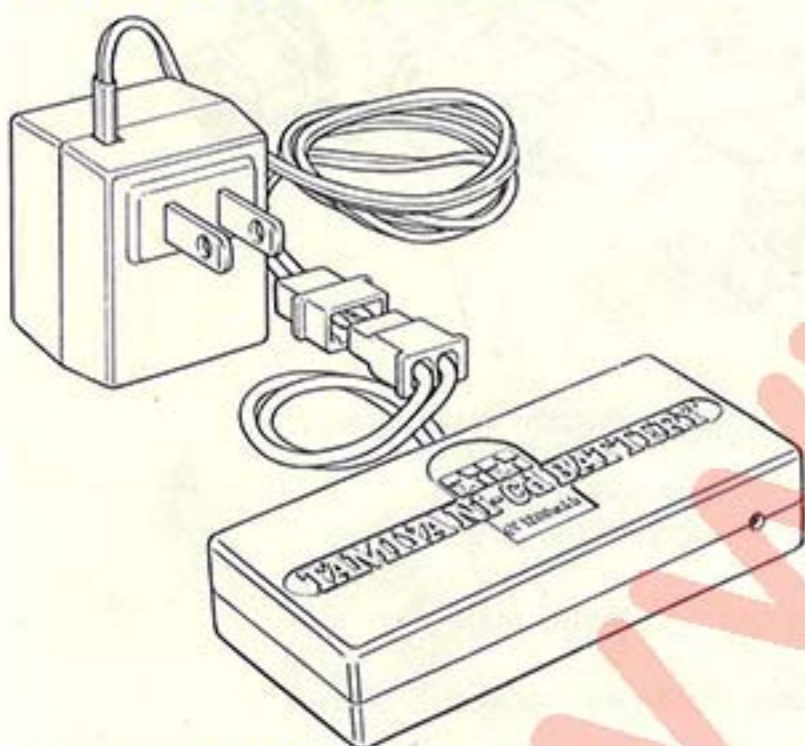

Tamiya Ni-Cd 7.2V-1200mAh Battery  
Tamiya NC 7.2V-1200mAh Akku

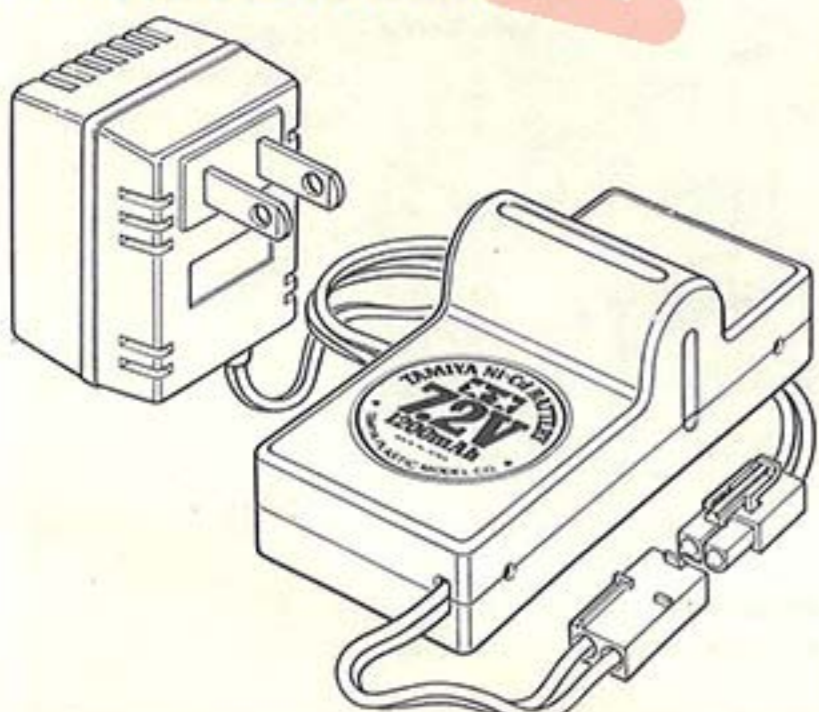

**2** How to install 6V or 7.2V 1200mAh Battery  
Einbau des 6V oder 7.2V 1200mAh Akkus

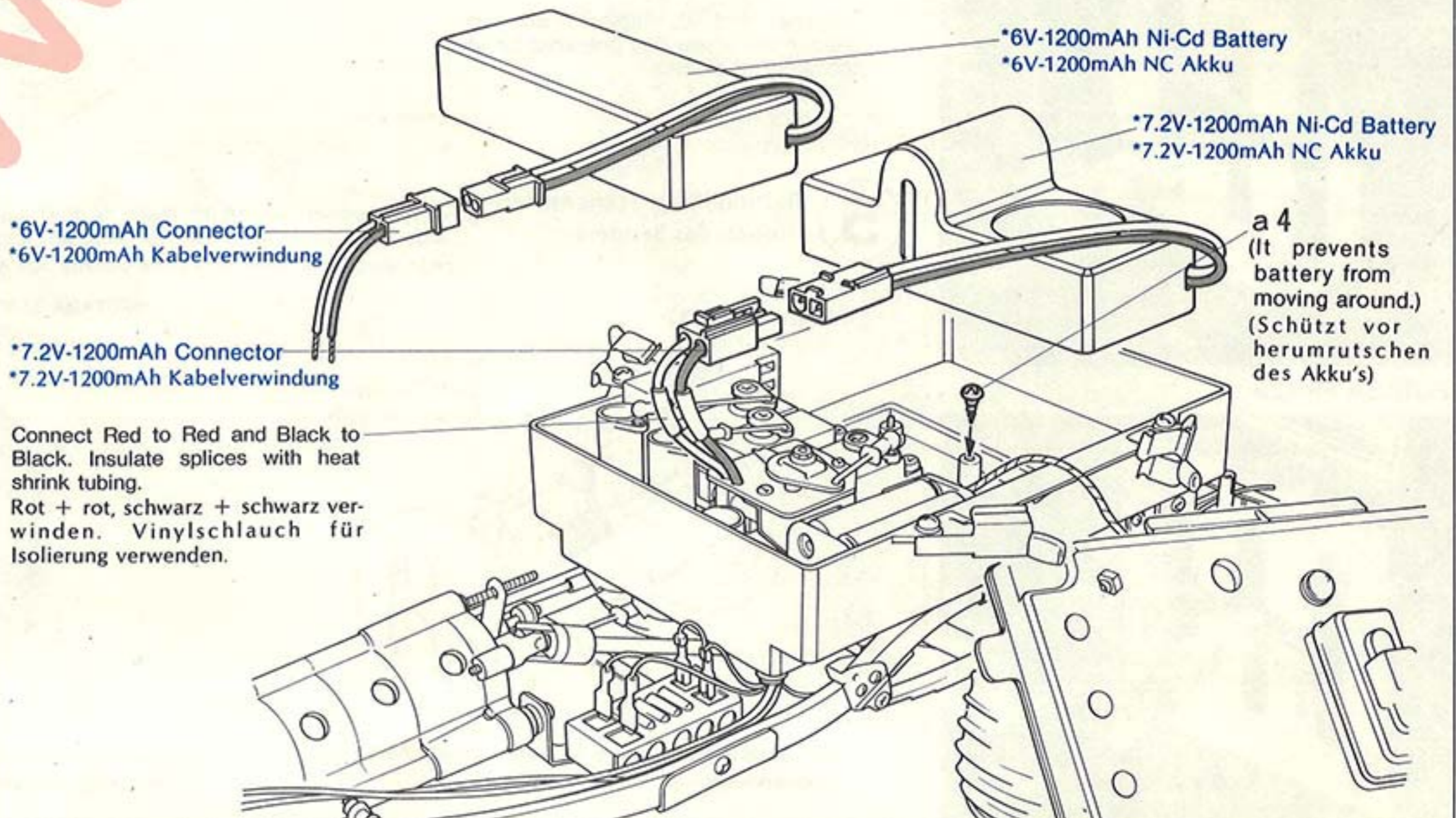

\*6V-1200mAh Connector  
\*6V-1200mAh Kabelverwindung

\*7.2V-1200mAh Connector  
\*7.2V-1200mAh Kabelverwindung

Connect Red to Red and Black to Black. Insulate splices with heat shrink tubing.  
Rot + rot, schwarz + schwarz verwinden. Vinylschlauch für Isolierung verwenden.

\*6V-1200mAh Ni-Cd Battery  
\*6V-1200mAh NC Akku

\*7.2V-1200mAh Ni-Cd Battery  
\*7.2V-1200mAh NC Akku

a 4  
(It prevents battery from moving around.)  
(Schützt vor herumrutschen des Akkus)

### 3 <<2 Channel 2 Servo Radio Installation>> <<Einbau der 2 Kanal Anlage mit 2 Servo's>>

You can enjoy driving with a 2 channel RC unit, too. In this case, shifting servo is not used, therefore, you must change gears by hand. Gear position is fixed while running. Decide gear position referring to the drawings at right prior to running.

In diesem Falle entfällt die Servoschaltung und man muss mit der Hand schalten.

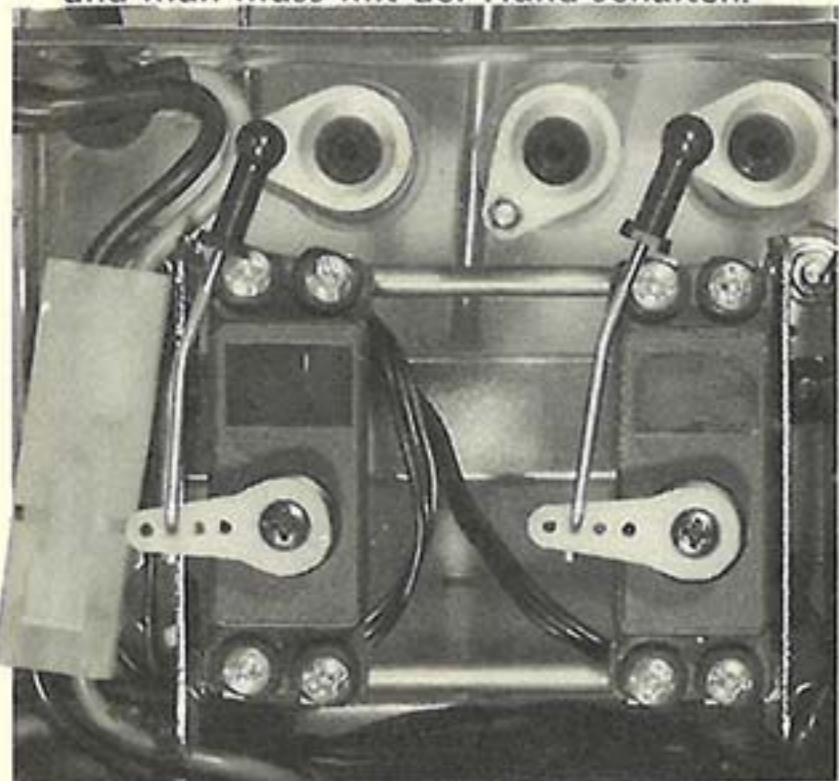

### 3 When 2 Channel 2 Servo Unit is installed Zwei Kanal - Zwei Servo Anlage

Gear shifting is available by hand only.  
Gangschaltung nur durch Hand

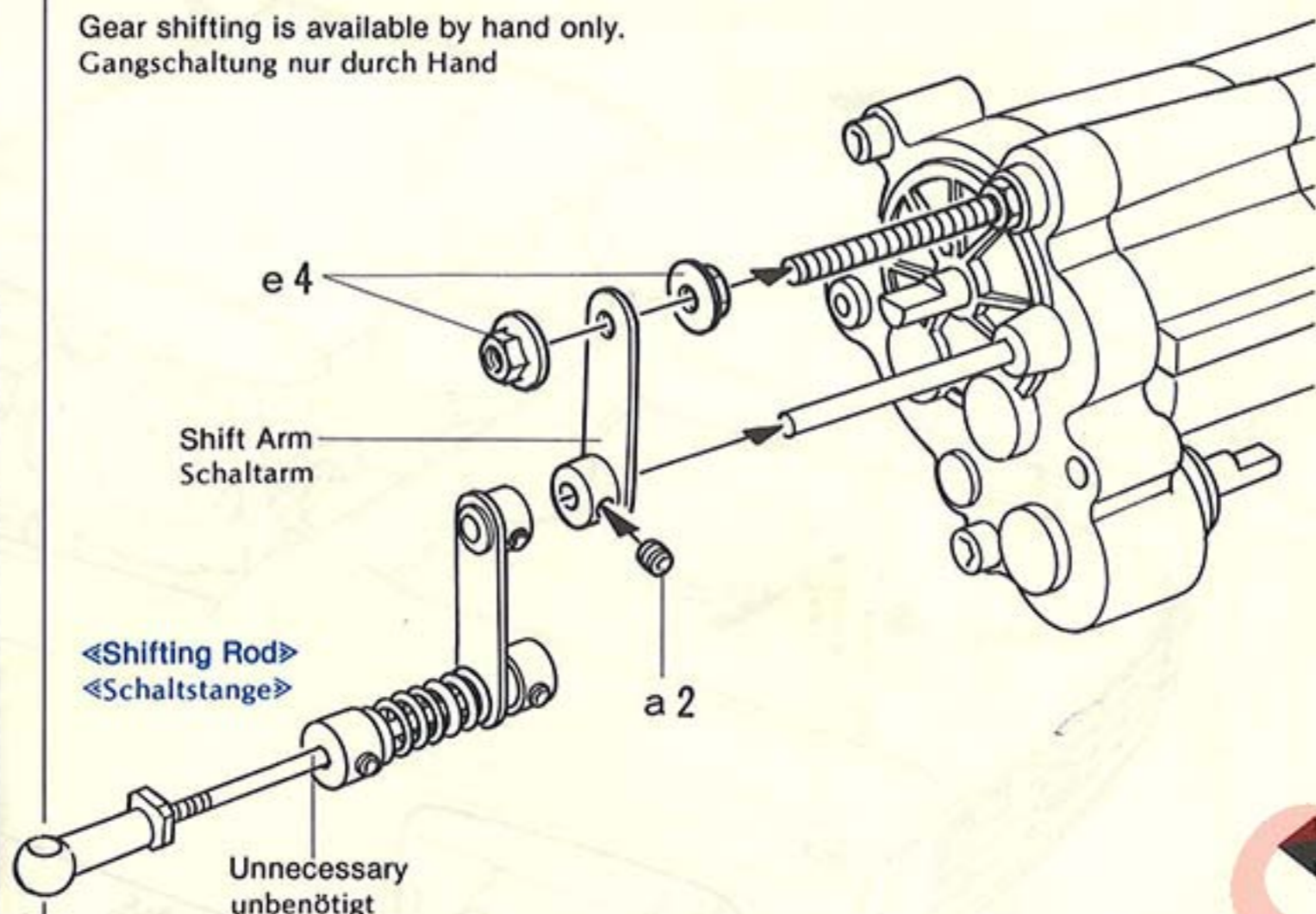

<<Second>>  
<<2. Gang>>

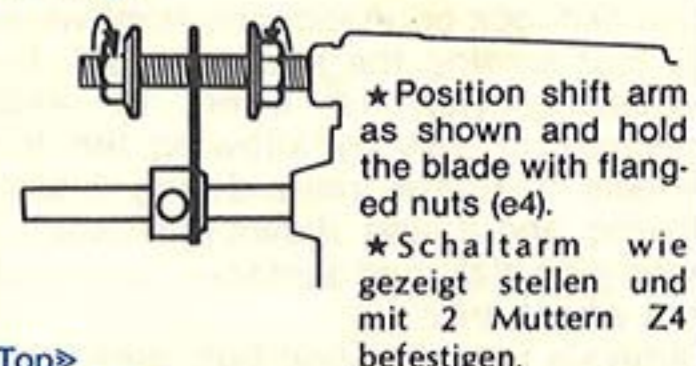

<<Top>>  
<<Topspeed>>

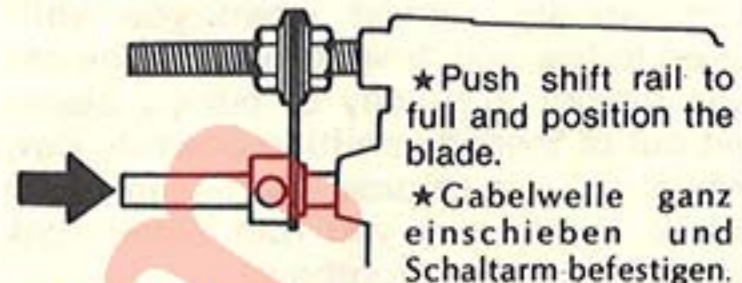

<<Low (4 Wheel Drive)>>  
<<Langsam (4 Radantrieb)>>

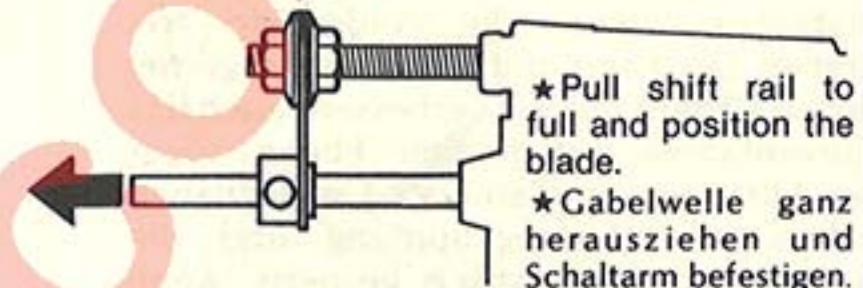

### 4 <<Oil Shock Absorbers>> <<Öl Stossdämpfer>>

To achieve higher driving performance, you can attach optional shock absorbers available with Tamiya RC tune-up parts (SP-1118). By using a denser oil for these shocks, you can improve shock power.

Der Einbau von Stossdämpfern (SP-1118 - nicht im Kit enthalten) erhöht das Dämpfen von Unebenheiten.

### 5 <<Shift Gate Assembly>> <<Schaltung>>

You can change gears and running speed by manipulating left stick of the transmitter. It is recommended to make a shift gate out of plastic or aluminum sheet according to the full sized drawings on insert.

Attach in position as shown at right. Die Geschwindigkeit wird durch eine Gangschaltung reguliert (linker Steuerhebel and der RC Anlage) Es wird empfohlen, dass Schaltschema aus Alu oder Plastik zu machen (Siehe Insert 20) Die Anbringung ist rechts abgebildet.

<<ACOMS AP-440FM-AP427>>



<<SANWA 4 CH SM391 SERVO>>

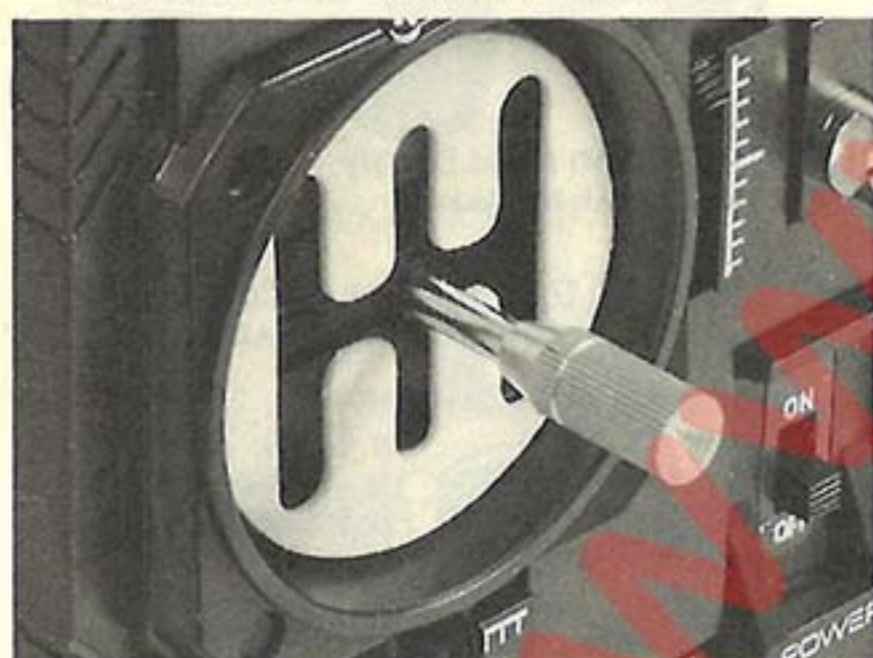

<<FUTABA FP-4L>>

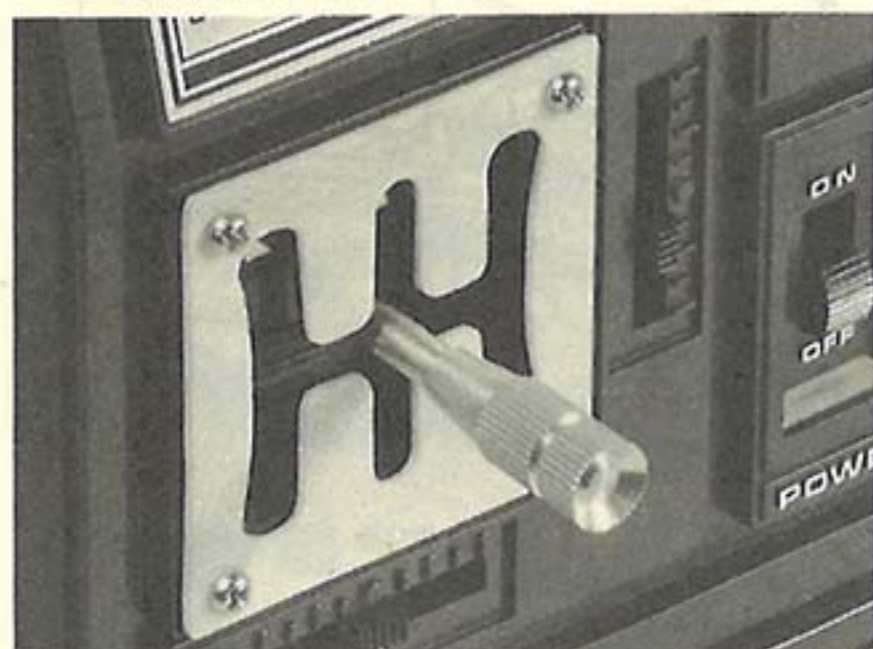

### 4 How to attach Shock Absorbers (Optional) Einbau Stossdämpfer (SP-1118 nicht im Kit enthalten)

<<Front>>  
<<Vorder>>  
\* Attach short shocks.  
\* Kurzer Stossdämpfer einbauen.

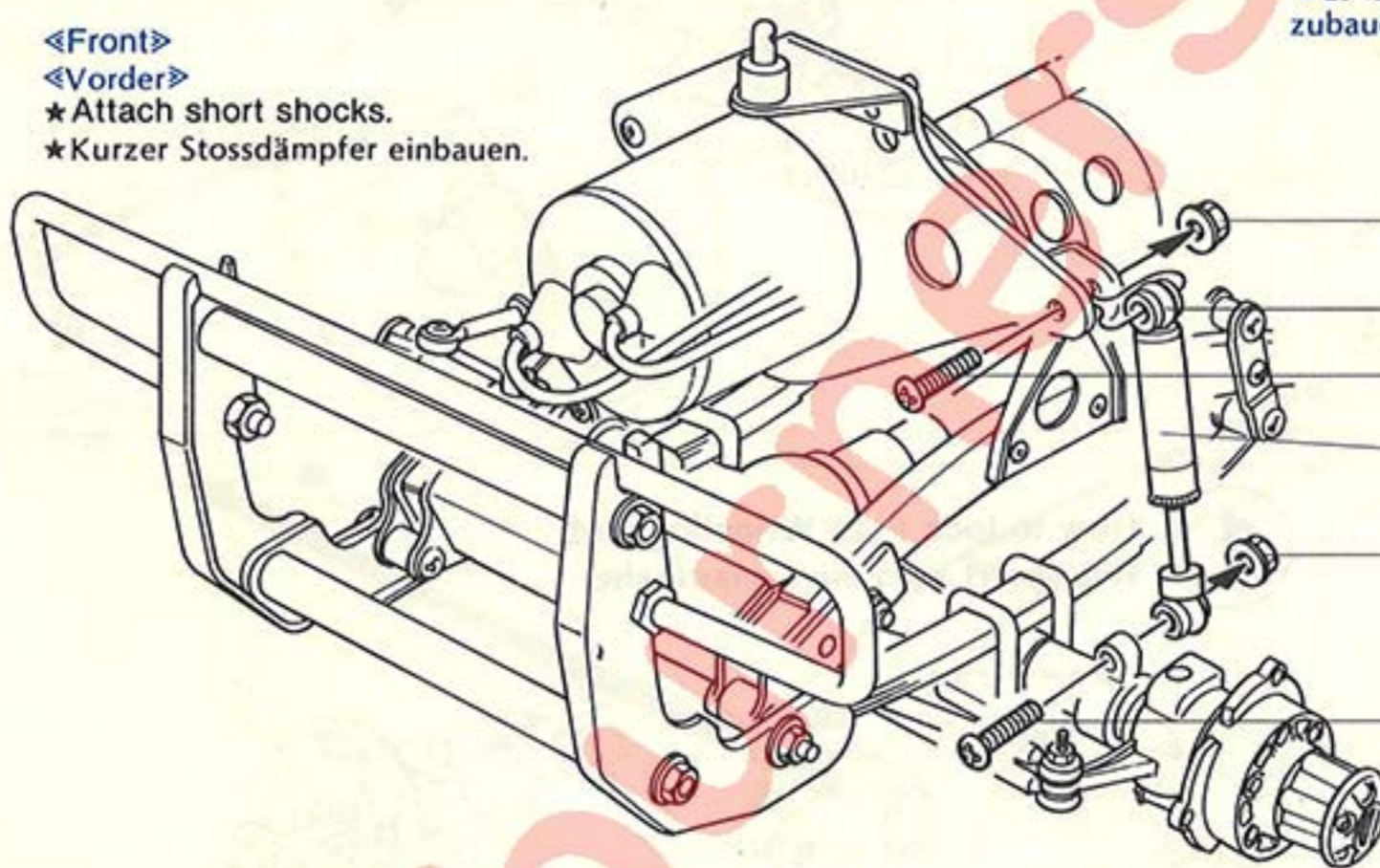

\* It is possible to attach optional shock absorbers (SP-1118) to make the suspension more effective.  
\* Es ist möglich, Stossdämpfer (SP-1118) einzubauen und die Federung zu verbessern.

\* Shock Absorber (short).  
\* Stossdämpfer (Kurz)

Decal 18  
Abziehbild



Replace d5 with 3mm x 15 Screw  
Statt d5 - 3mm x 15 Schraube nehmen.

<<Rear>>  
<<Hinte>>  
\* Attach long shocks.  
\* Langer Stossdämpfer einbauen.

Decal 18  
Abziehbild



3mm Flanged Nut

3mm Flanged Nut

\* Screws and nut marked 3 are supplied in the screw bag prepared for attachment of shocks.

3mm x 20 Screw 3mm x 27 Screw  
3mm Nut

3mm Flanged Nut

Shock Absorber (long)  
Stossdämpfer (lang)

### 5 Remodelling Transmitter Umbau des Senders

\* It is recommended to make a shift pattern out of plastic plate or aluminum sheet as shown for easy shifting.  
\* Es wird empfohlen, das Schaltschema aus Alu oder Plastik zu machen.

<<SANWA-ACOMS>>

<<FUTABA-MRC>>

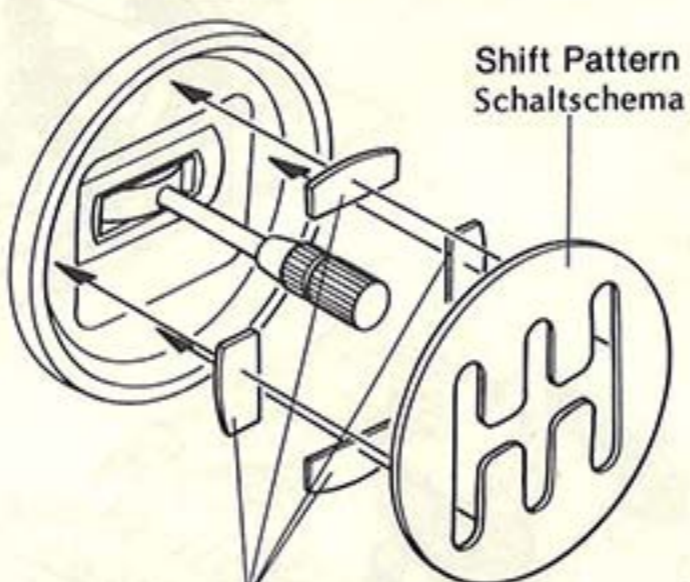

Use double sided servo tapes for attachment.  
Doppelklebeband

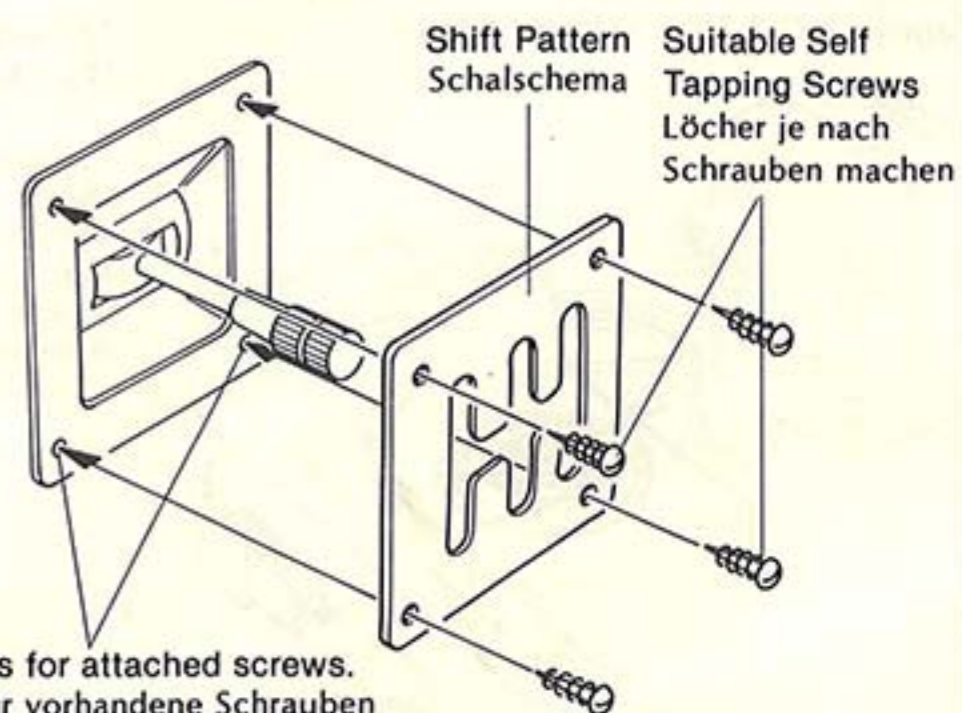

Use holes for attached screws.  
Löcher für vorhandene Schrauben



# 4X4 BLAZING BLAZER



## «Inspection before Operation»

Be sure to check the points shown in the figure before starting operation. This is necessary to prevent trouble and accidents.

It is recommended to check them with the model put on a base as shown in the figure so that the wheels are in the air.

In the first operation after assembly, let the model run slowly for the first five minutes while checking the condition of the steering and switch.

- 1 Make sure that screws, particularly grub screws, are tight enough.
- 2 Make sure that batteries for the transmitter and receiver are new by means of meter or lamp.
- 3 Make sure that Ni-Cd battery has been sufficiently charged.
- 4 Adjust steering servo and/or trims so that the car tracks in a straight line with transmitter at neutral.
- 5 Double check the speed controller for full travel to high speed and stop limits.
- 6 Does the Transmission shift gear to low, second and high properly?
- 7 Double check the wiring for breaks and short circuits. Secure with vinyl tape.
- 8 Did you oil all bearings? Be sure to do so prior to running.

## «Einlaufen»

Nach Zusammenbau das Modell langsam die ersten 5 Minuten laufen lassen und dabei die Steuerung und Schalter auf gute Wirkung beobachten.

- 1 Darauf achten, dass alle Schrauben gut angezogen sind.
- 2 Batterien für Empfänger und Sender müssen voll sein.
- 3 Nur volle Akku's bringen volle Leistung evtl. nachladen.
- 4 Steuerung muss einwandfrei arbeiten. Modell muss geradeaus fahren. Wenn Fahrzeug nach links oder rechts zieht, mit Trimmhebel nach justieren.
- 5 Der Schalter muss auf Topspeed gehen und genau stoppen.
- 6 Schaltet das Getriebe auf langsam, 2. Gang oder schnell einwandfrei?
- 7 Kabel gut isolieren um Kurzschluss zu vermeiden.
- 8 Sind all Lage geölt? Vor Fahren, alles gut ölen.

## «Procedure for Running»

1. Set up batteries for the motor, transmitter and receiver.
2. Make sure that the sticks and trim levers of the transmitter are in neutral.
3. Turn on the transmitter switch.
4. Turn on the receiver switch.
5. Confirm the movement of each portion by manipulating the sticks. Make adjustment by means of the trim levers, if necessary.

★ The switches must be operated in this order. If the receiver switch is turned on before the transmitter switch, the model may go out of control because of interference.

★ Reverse the procedure mentioned above when you finish running the model. Turn off the receiver switch, then transmitter switch. Remove the batteries if the model is not going to be used for a while.

★ Never run your car near children or in crowded place. Be careful of driving area since it could involve personnel injury.

## «Fahren»

1. Akku und Batterien für Fahrzeug. Sender und Empfänger einsetzen.

2. Darauf achten, dass Hebel am Sender auf neutral stehen.

3. Sender einschalten.

4. Empfänger einschalten.

5. Servos müssen einwandfrei arbeiten, evtl. Trimmung nachjustieren.

★ Es ist unbedingt notwendig, dass erst der Sender eingeschaltet wird und dann der Empfänger.

Macht man dies in anderer Folge, kann das Fahrzeug ausser Kontrolle geraten.

★ Bei Einstellen des Fahrbetriebes erst Empfänger dann Sender ausschalten.

★ Akku und Batterien entfernen, evtl. nachladen.

★ Das Fahrzeug nicht in die Nähe von Kindern fahren. Vorsicht, Sie fahren auf eigenes Risiko oder Gefahr.

## TROUBLESHOOTING

If the car does not run well, try the following:

- 1 When the gear does not shift to low, second or high well, check the servo stroke, rod length and movement from servo horn to shift arm. Readjust each section from beginning referring to "Gear Shift Adjustment" on Page 11.
- 2 If the motor does not function (a rare occurrence), remove wires and check the motor by directly connecting its lead wire to a fresh battery.
- 3 Is the servo arm in the proper position? It must be fitted so that the model turns right and left the same amount.
- 4 If oil supply is not enough, sometimes shaft and bearings overheat. Apply grease and oil to the shaft and shaft holders. If the shaft has overheated, take out the shaft from the car, and polish it to ensure smooth rotation.
- 5 When shaft or wheels become entangled, motor will overheat. Remove such hinderances immediately.
- 6 Antenna must be adjusted correctly.

7 If the servo moves abnormally when the receiver switch is on, and the transmitter switch is off, another transmitter is causing interference.

8 If the Radio Control Unit is not satisfactory, enquire with the manufacturer. The radio control unit is very precisely constructed and must be handled with great care.

## STORUNGEN UND URSACHEN

1 Wenn das Getriebe nicht auf langsam, 2. Gang oder schnell schaltet, den Servoausschlag überprüfen. Die Schubstangenlänge und die Bewegung des Servohornes, sowie des Schaltarmes überprüfen. Evtl. nochmals nachstellen.

2 Wenn Motor nicht läuft, evtl. direkt an Batterie zum Prüfen anschließen.

3 Das Servoarm überprüfen. Es muss so eingebaut sein, dass links und rechts gleichmässige Drehung erfolgt.

4 Alle drehbaren Teile müssen immer gefettet sein. Wenn Antriebswelle überhitzt ist, ausbauen, glätten und neu schmieren.

5 Wenn Gras oder Steinchen die Antriebsachsen blockieren, wird der Motor überhitzt. Blockierung sofort entfernen.

6 Antenne richtig setzen.

7 Wenn sich Servos bewegen wenn Schalter auf "aus" — herrscht Wellensalat — ein anderer Sender stört.

8 Wenn Funkanlage nicht richtig arbeitet, zum Fachhändler gehen — NICHT versuchen, SELBST zu reparieren.

## «Caution»

R/C equipment, motor and battery are subject to problems if wet. If the car gets wet, wipe off well and dry in an airy place.

★ Front and rear axles should be overhauled and re-oiled after getting wet.

★ It is all right to change from forward to reverse in the same gear position, but avoid changing to forward or reverse while shifting gears up or down. It could damage transmission seriously.

## «Vorsicht!»

Wenn RC Anlage, Motor oder Akku nass werden, können Troubles auftreten. Wenn etwas nass wird, Wasser abwischen und Fahrzeug an luftiger Stelle trocknen lassen. Vorder und Hinterachse überholen und neu ölen.

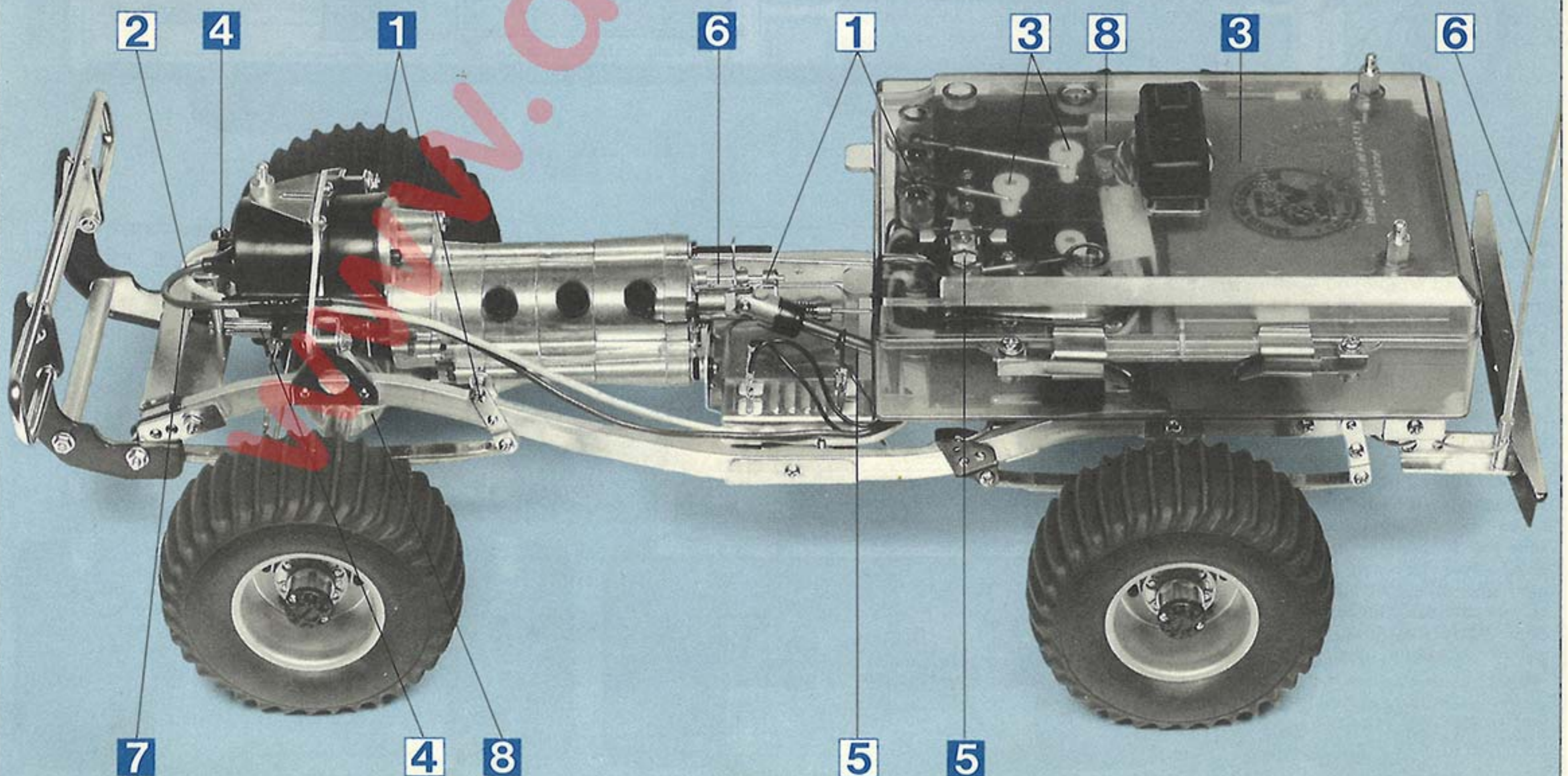

# PAINTING & MARKING

## «Painting»

The painting diagram shown at right is only an example. Use this as a guide in making up your own paint scheme and add the decals to suit your tastes.

Da es mehr oder weniger ein Hobby-Fahrzeug ist, kann es je nach Wunsch, bemalt werden.

Sticker und Streifen sind im Kit enthalten.

Vorsicht-bei Verwendung von Klarlack könnten die Abziehbilder beschädigt werden. Erst auf Reststücken

## «Spray painting hints»

Firstly always spray indoors in windless and dust-free conditions. Spread paper under your work. Mix the paint well by shaking the can for three minutes and then test spray against some cardboard from about 20cm, checking that the paint is properly mixed. When spraying the car body, hold the can about 20cm from the plastic, moving the can quickly always in the same direction and ensure an every application. A good tip is to imagine you are spraying a large surface, i.e. the surrounding paper you will then probably achieve a more even finish.

★In using the aerosol spray, be sure to follow the instructions printed on the container. Never use it near fire.

## «Bemalung mit Sprayfarben»

Nur in zug-und staubfreien Räumen spritzen. Teile auf ausgebreitete Zeitung stellen. Spraydose gut durchschütteln (3 Min) und durch Spritzen auf Karton prüfen, ob Farbe gut gemischt ist. (20cm Abstand). Das Modell in gleicher Richtung grossflächig besprühen. **Keine Sprayfarben auf Nitrobasis sondern nur Sprayfarben für Polystyrol** plastik verwenden. Bei Verwendung von Sprayfarben auf die Anleitung achten. Nicht in Nähe von Feuer sprühen.

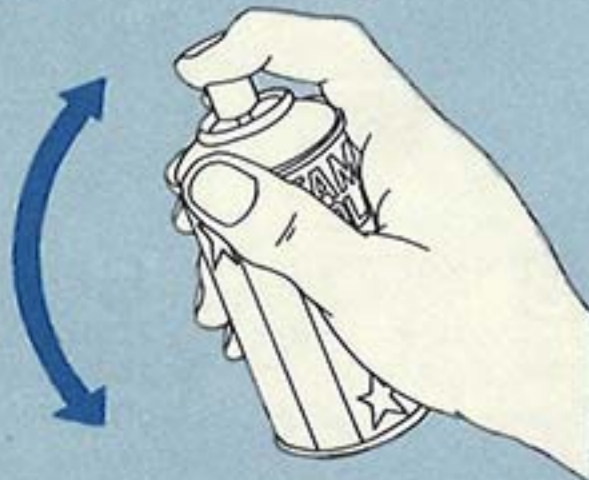

## «Painting with masking tape»

When the paint is completely dry, apply masking tape or sticky paper (not cellophane tape) over the whole area of the body. Draw out the required shape you want onto the paper with a hard pencil then cut the paper along the lines you have drawn very carefully. Then remove the paper not required to mask the body. Finally **press the mask firmly down onto the plastic to ensure it seals it from the paint.** Then paint as instructed in previous paragraphs.

## «Bemalung mit Klebeband»

Farbe muss vollkommen trocken sein. Nur Klebepapier oder Abdeckband verwenden - niemals Tesafilm - und gut anliegend aufkleben. Die zu bemalenden Flächen ausschneiden. Abdeckmaterial erst nach gutem Trocknen der Farbe entfernen.

## «Colors suitable for body painting»

Black	.....X-1
White	.....X-2
Royal Blue	.....X-3
Blue	.....X-4
Green	.....X-5
Orange	.....X-6
Red	.....X-7
Lemon Yellow	.....X-8
Metallic Blue	.....X-13
Flat Aluminum	.....XF-16
Metallic Grey	.....XF-56

## ★For interior painting

Flat Black	.....XF-1
White	.....X-2
Orange	.....X-6
Red	.....X-7
Red Brown	.....XF-64
Chrome Silver	

## «Marking»

(1) Decals are on seals of sticker tape. A decal to be applied should be cut off beforehand.

(2) Peel off the end of lining a little and put the decal in position on the body. Then, remove the lining slowly. In so doing, be careful that the decal does not move out of posi-

tion and that air is not trapped under it.

If the lining is completely removed in advance, the decal may be wrinkled or contain unwanted air bubbles.

## «Markierung»

Die Decals sind selbstklebend. Erst ausschneiden, dann anbringen. Das Schutzpapier etwas entfernen. Decals ansetzen und dann vorsichtig aufdrücken und Papier gleichzeitig abziehen. Wenn das Papier vorher ganz **abgezogen** wird, kann das Decal **zerknittern** oder es bilden sich **Blasen**.

## «Painting Example»

★ Apply decals ①—⑩ in order.

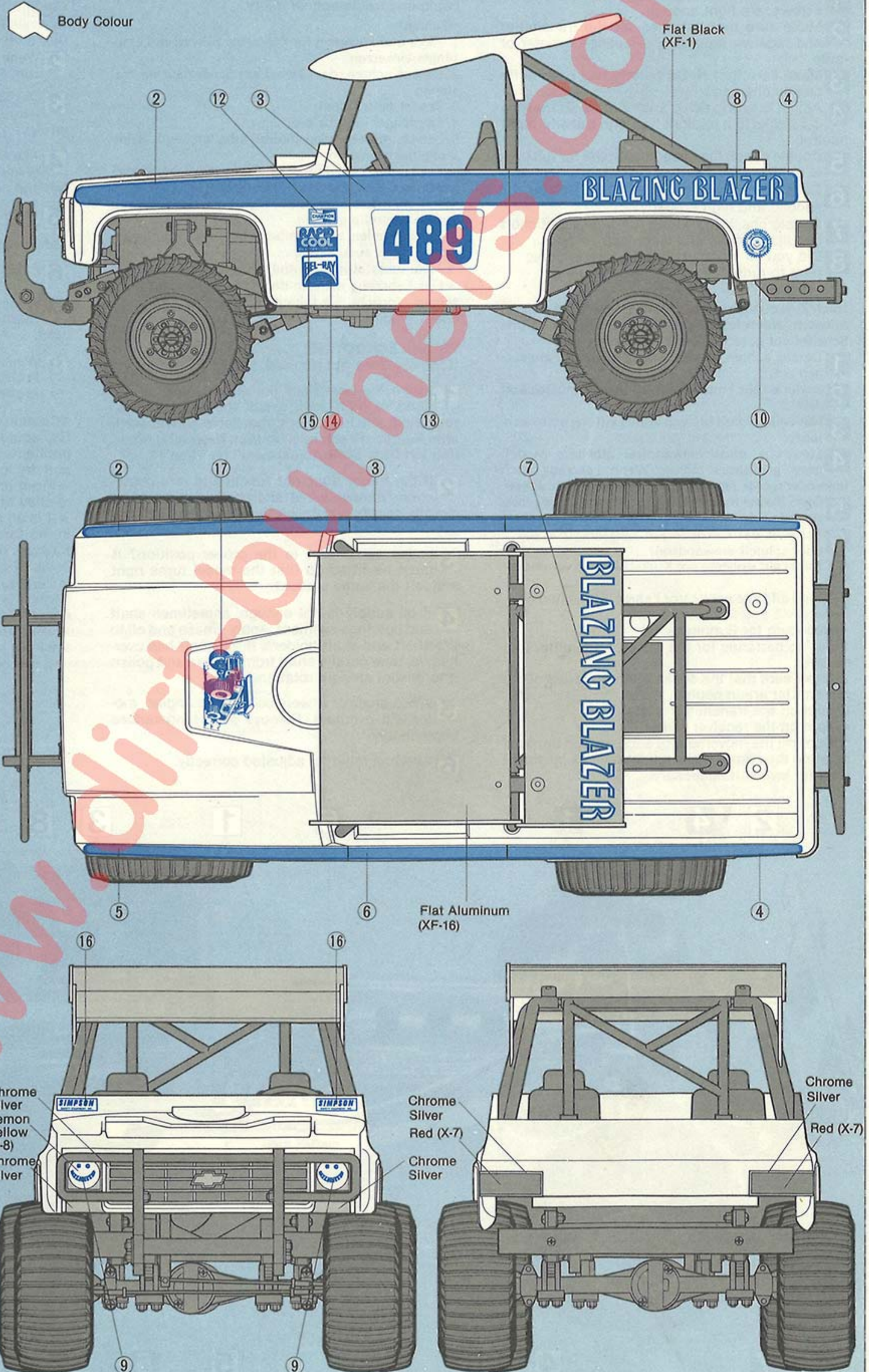

# PARTS

Extra screws and metal parts are included. Use them as spares.

Body  
Mechanism Box  
Mechanism Box Lid  
Antenna  
Decal

## A PARTS

Parts not used.

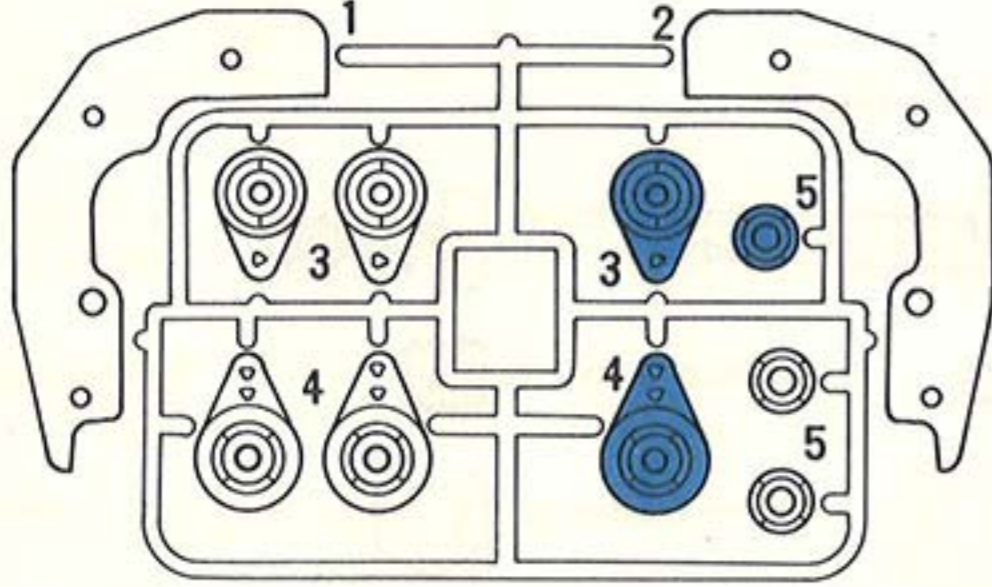

## B PARTS

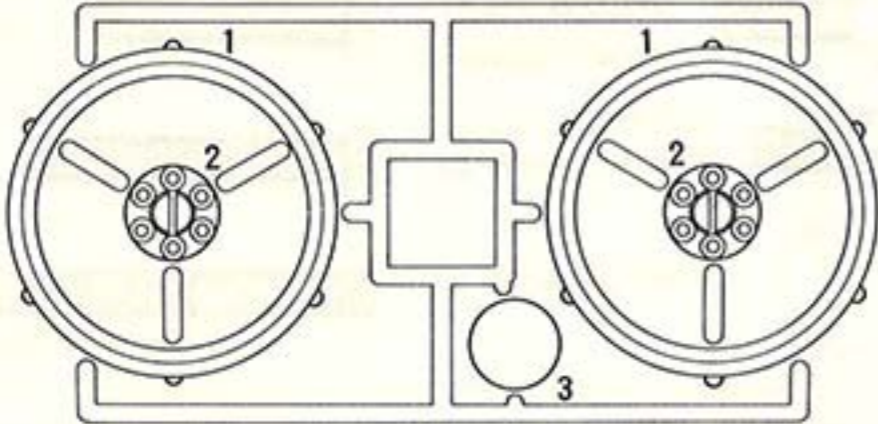

## D PARTS

- Body Colour
- Flat Aluminum (XF-16)
- Chrome Silver
- Red (X-7)
- Lemon Yellow (X-8)
- Flat Black (XF-1)

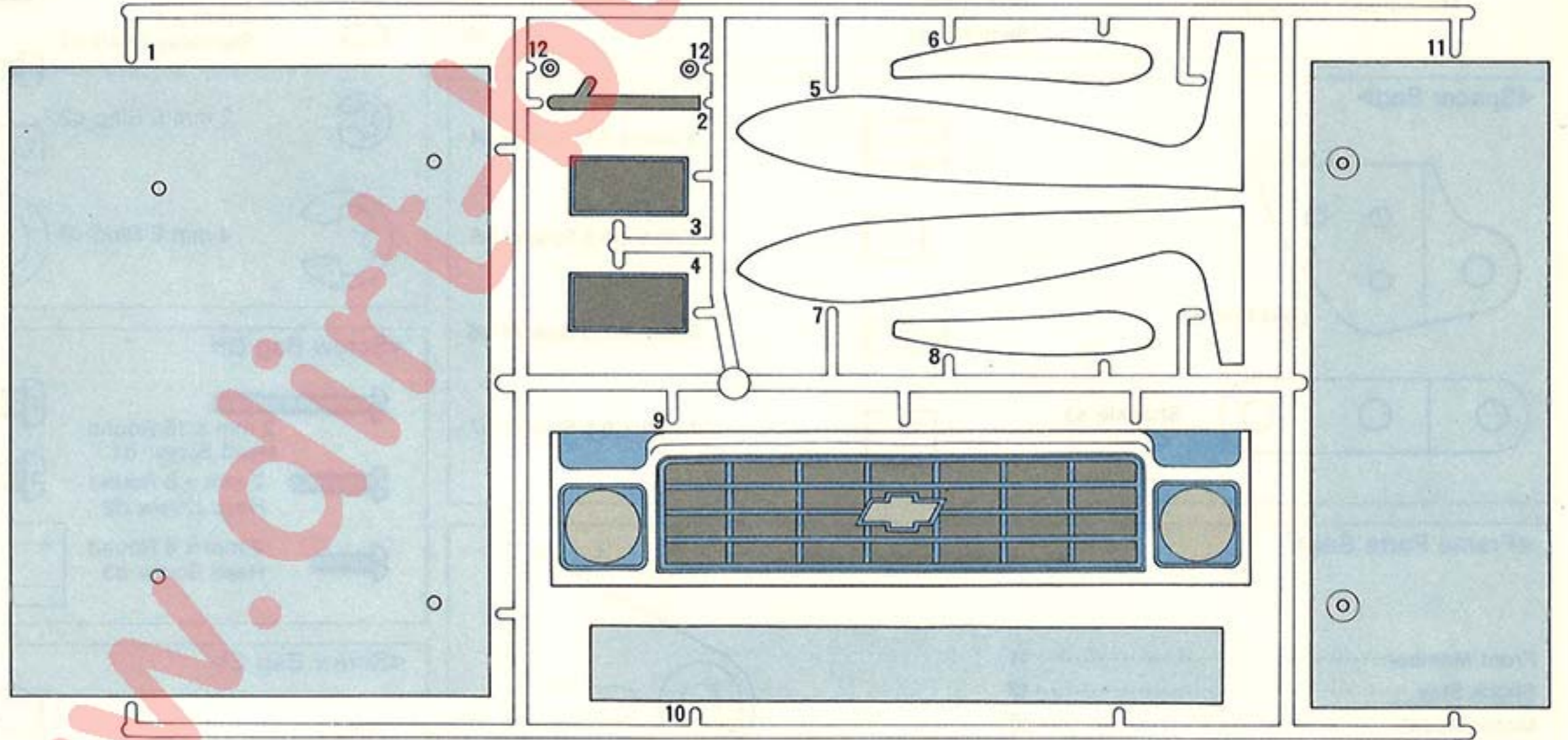

## E PARTS

Black (X-1)

## C PARTS

Flat Black (XF-1)  
 Flat Aluminum (XF-16)  
Parts not used.

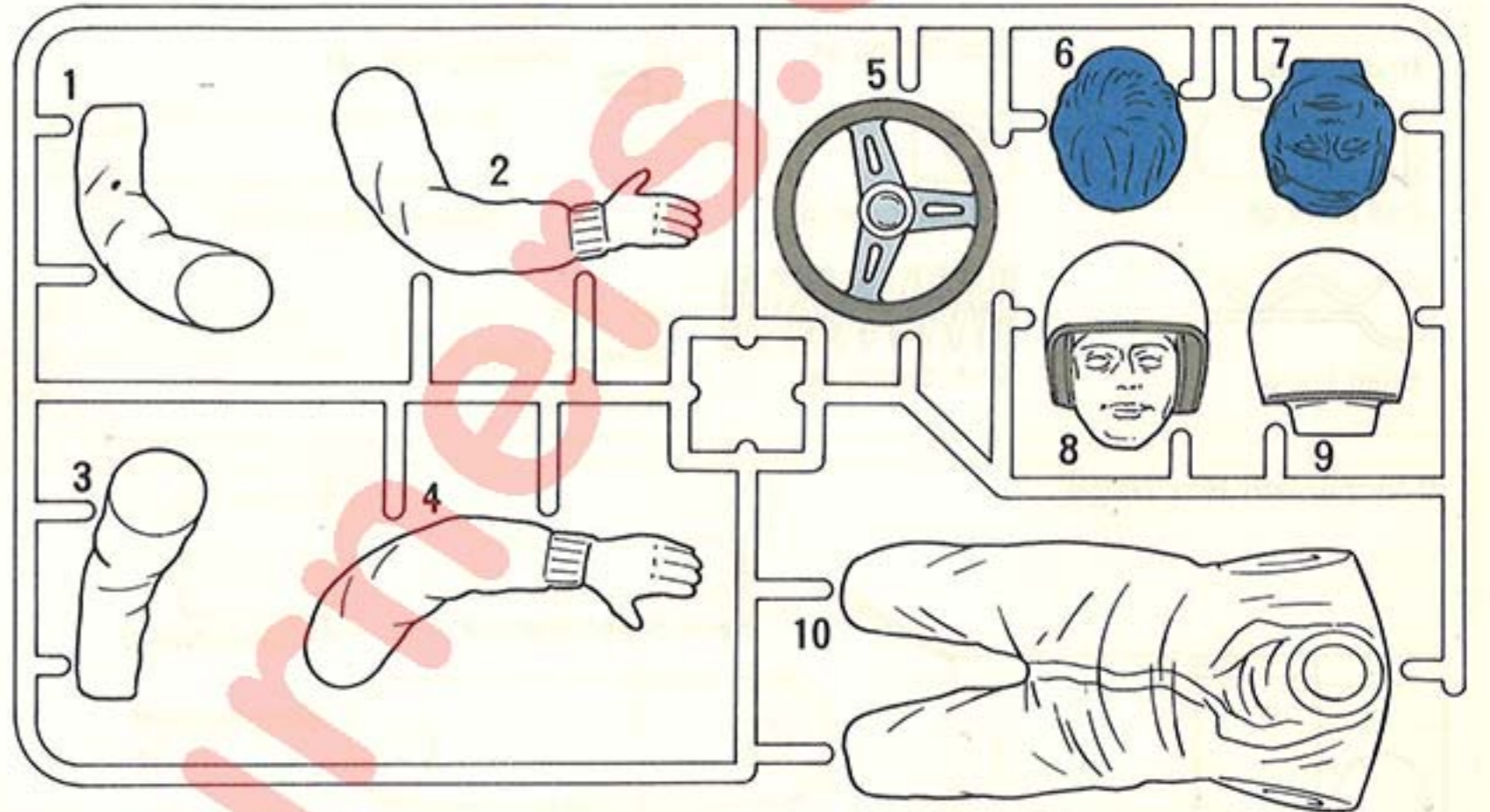
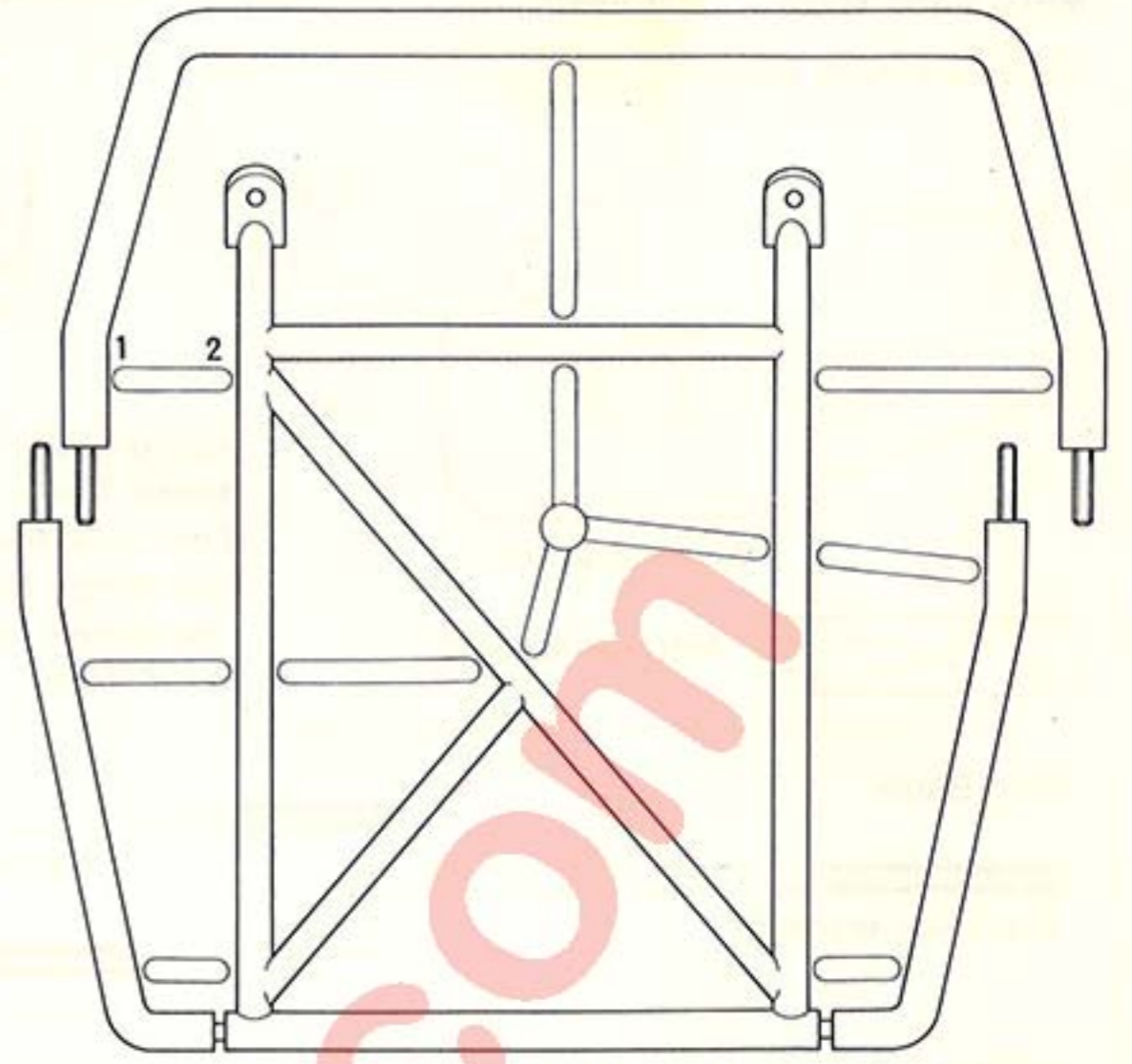

### <Blister Pack A>

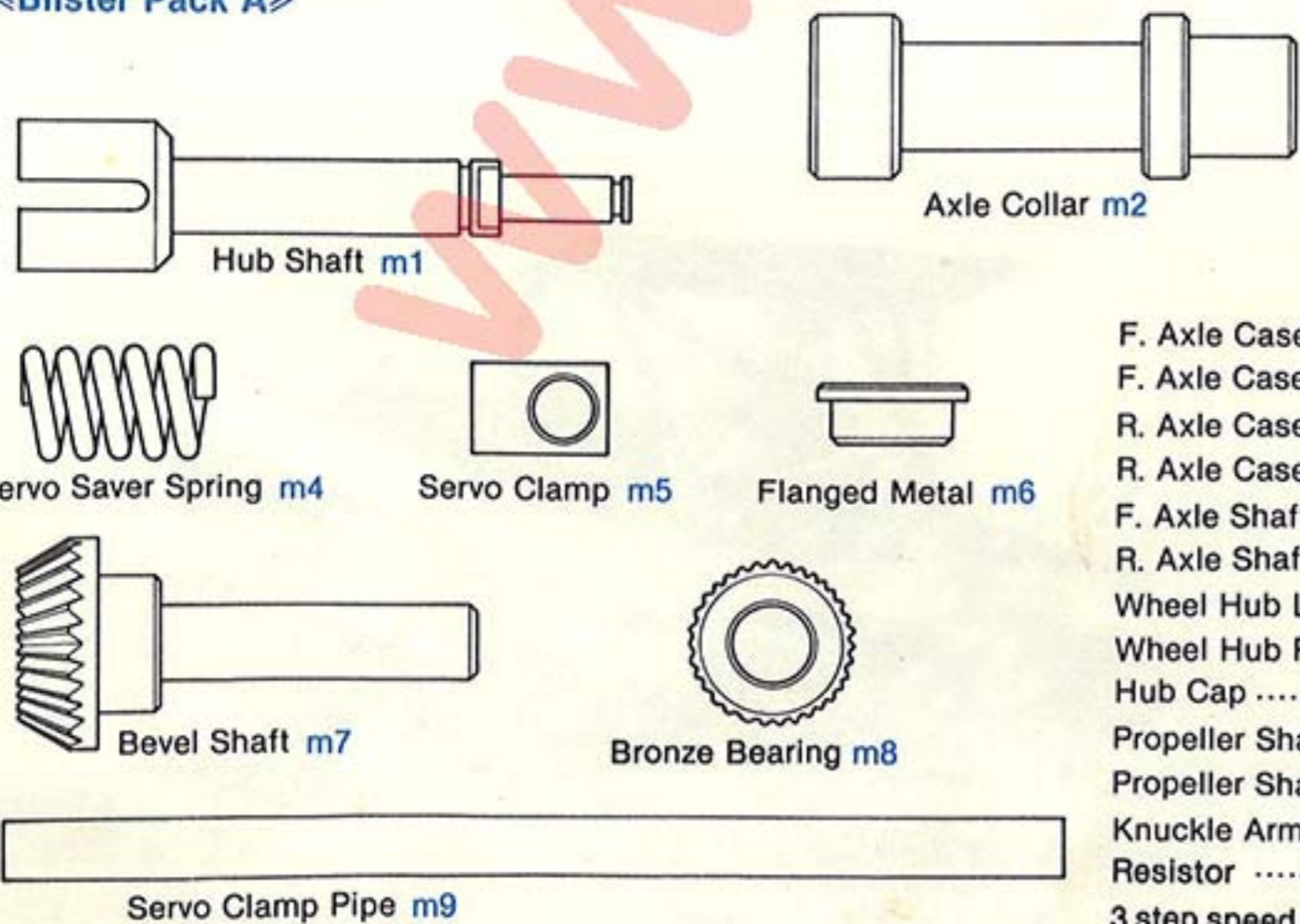

F. Axle Case A	m10
F. Axle Case B	m11
R. Axle Case A	m12
R. Axle Case B	m13
F. Axle Shaft	m14
R. Axle Shaft	m15
Wheel Hub L	m16
Wheel Hub R	m17
Hub Cap	m18
Propeller Shaft (short)	m19
Propeller Shaft (long)	m20
Knuckle Arm	m21
Resistor	m23
3 step speed controller	m24

### <Blister Pack B>

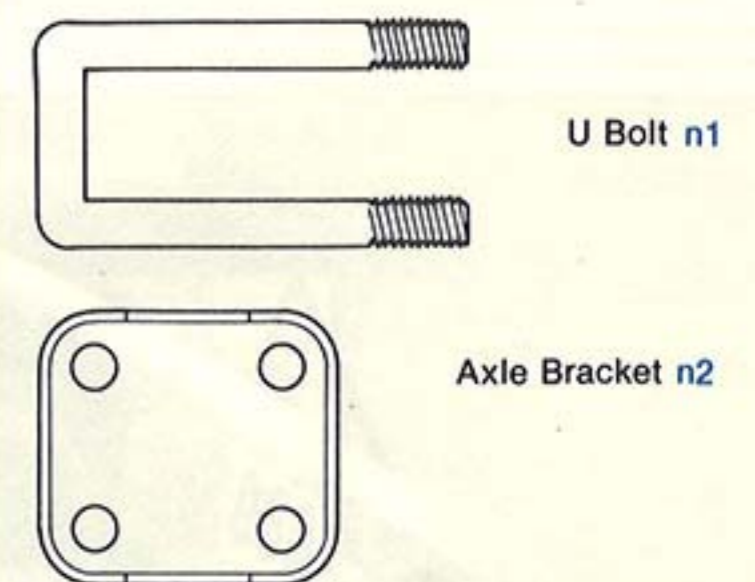

Frame L	n3
Frame R	n4
Leaf Spring	n5
Gear Box	n6
Aluminium Wheel (Inside)	n7
Aluminium Wheel (Outside)	n9
Tire	n10

«Bumper Parts Bag»

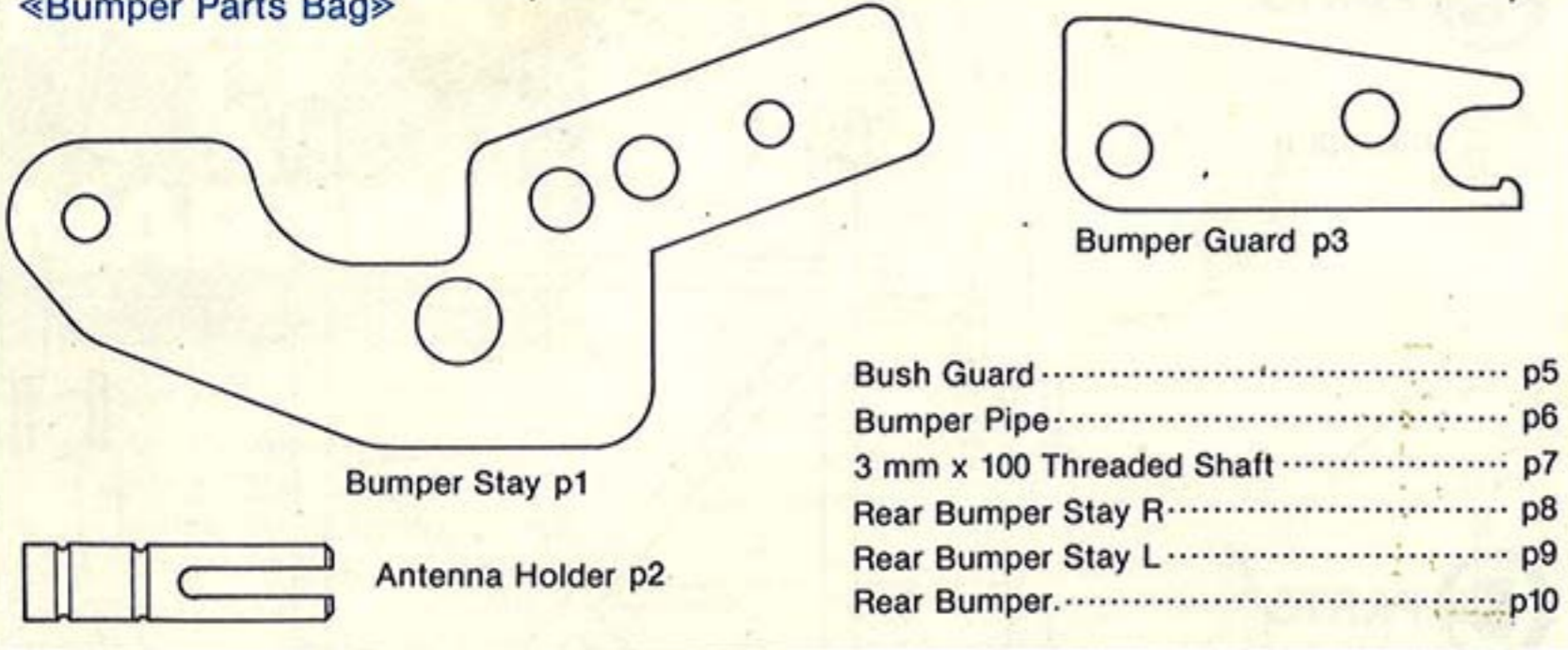

«Rod Bag»

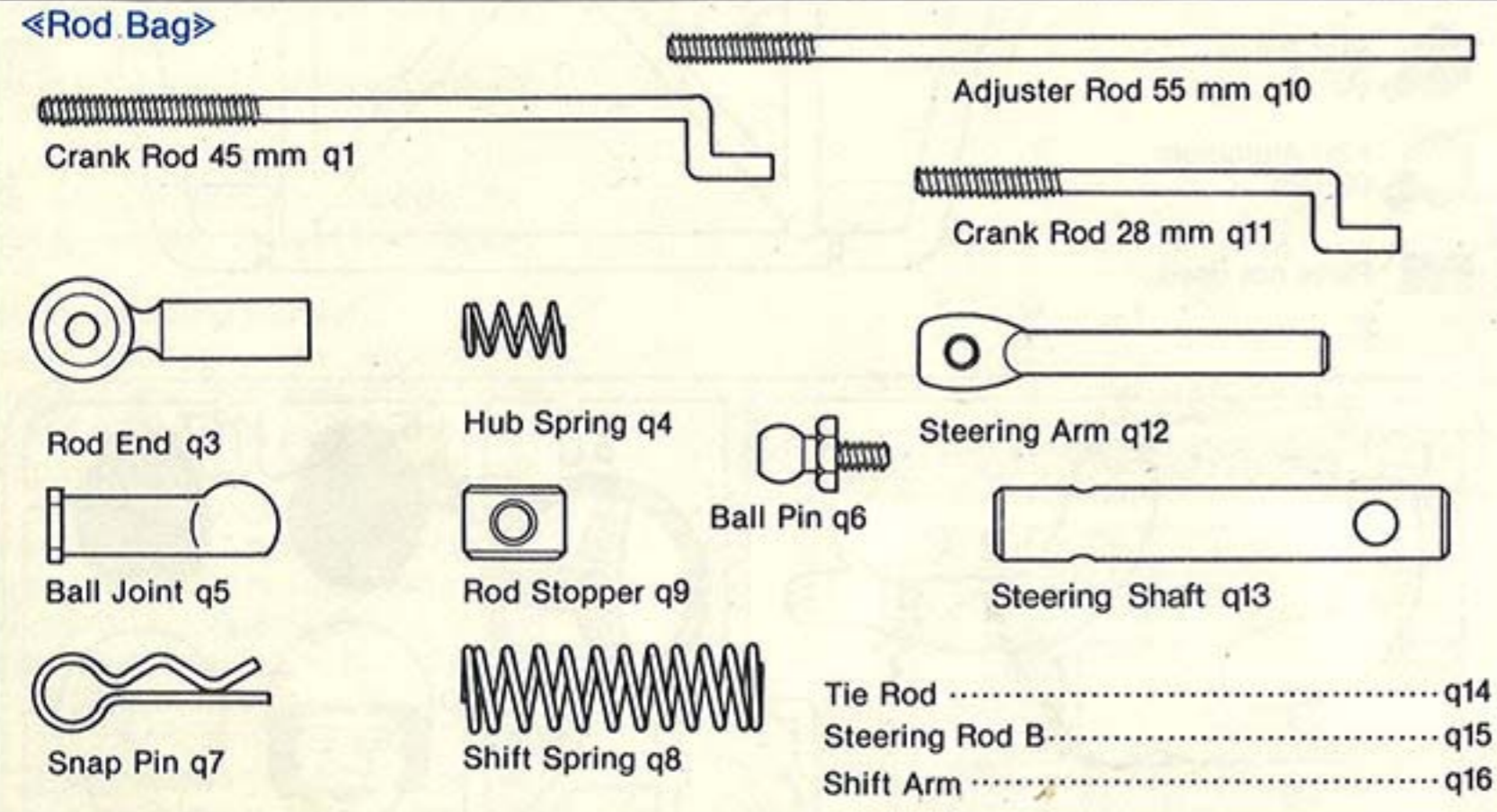

«Mechanism Box Bag»

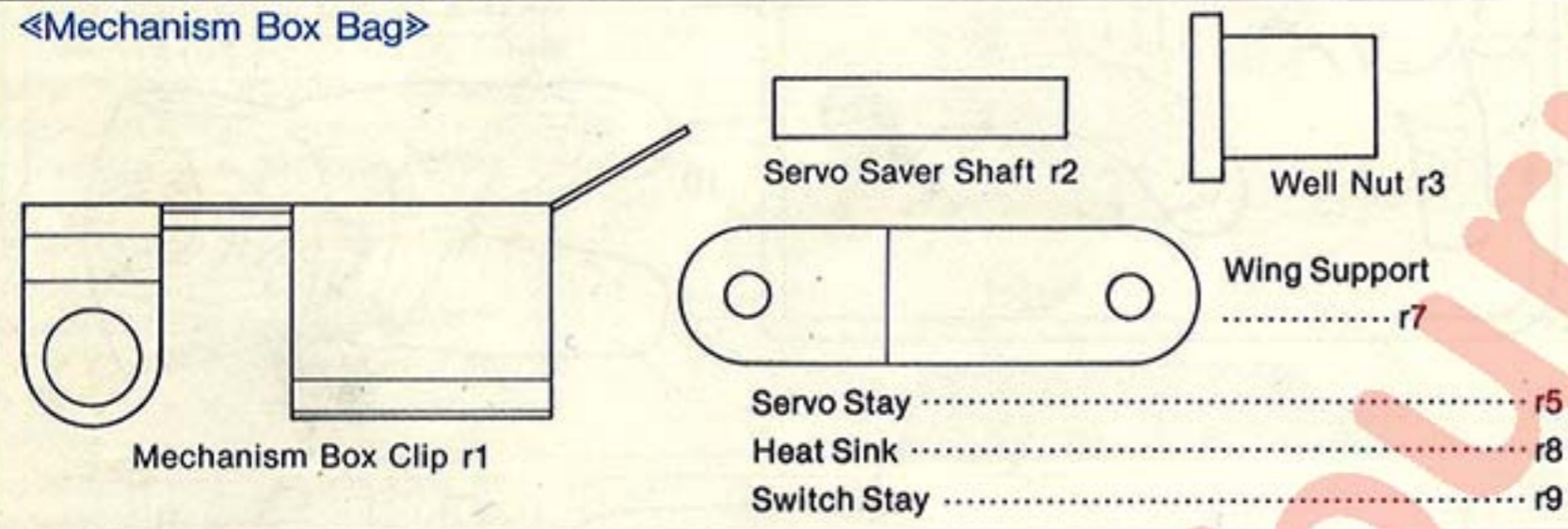

«Spacer Bag»

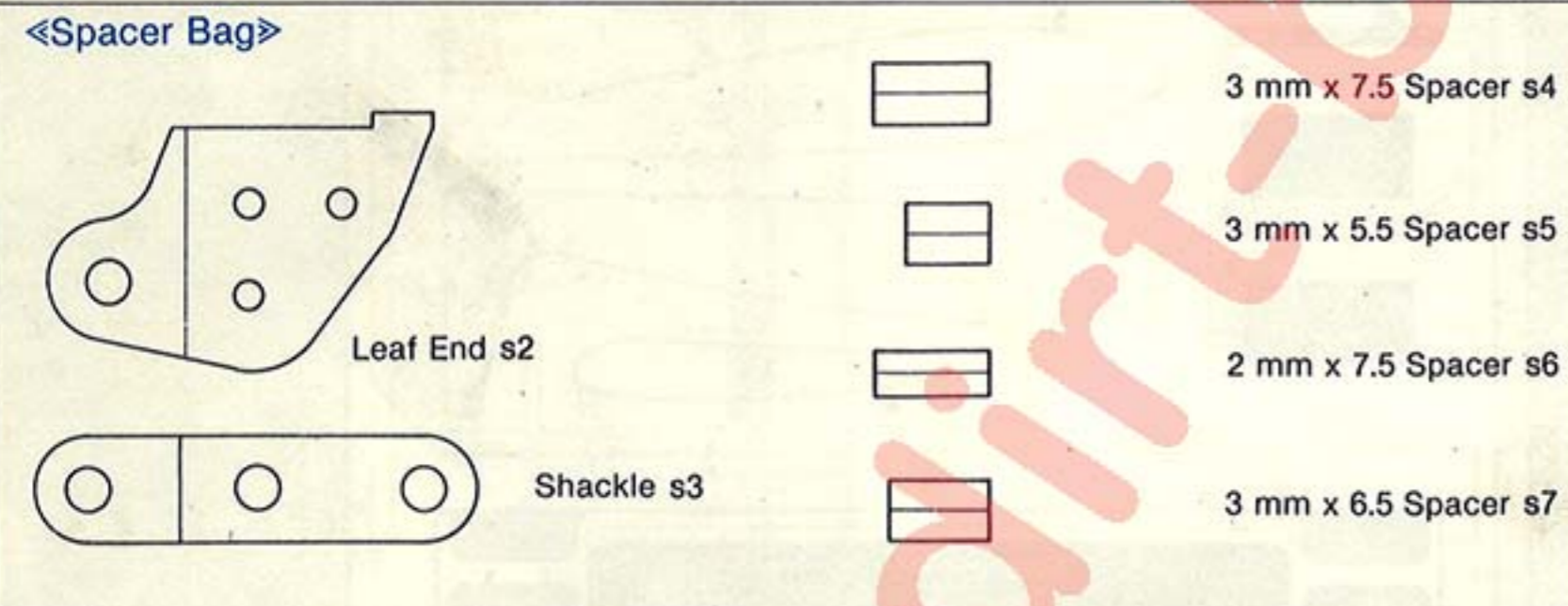

«Frame Parts Bag»

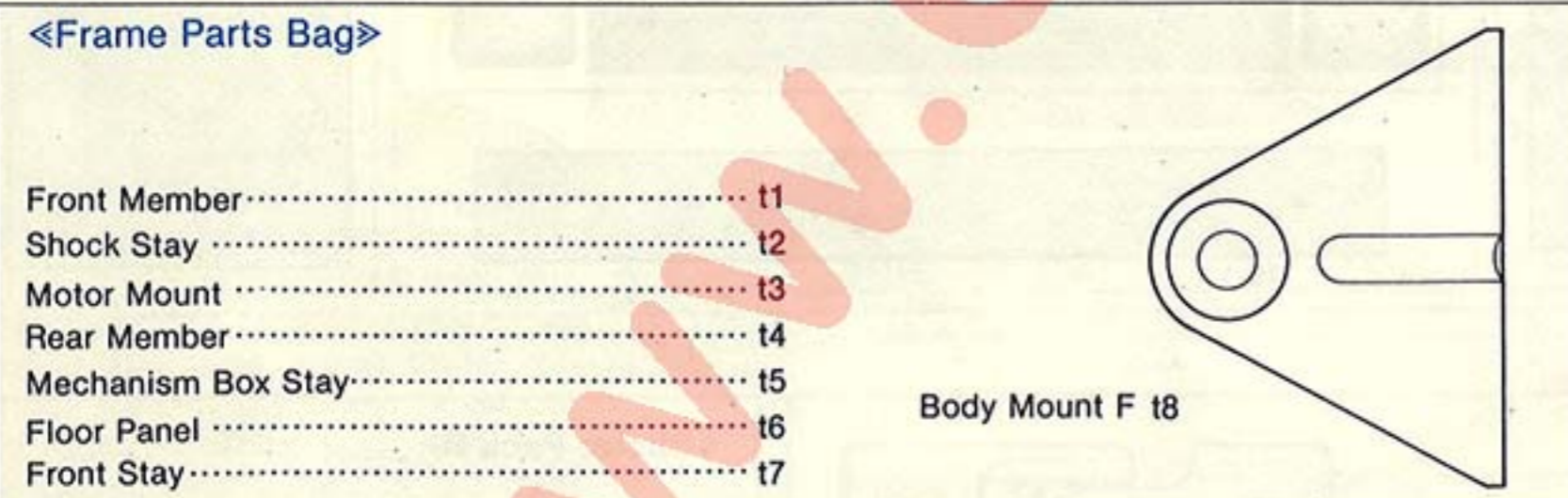

«Tool Bag»

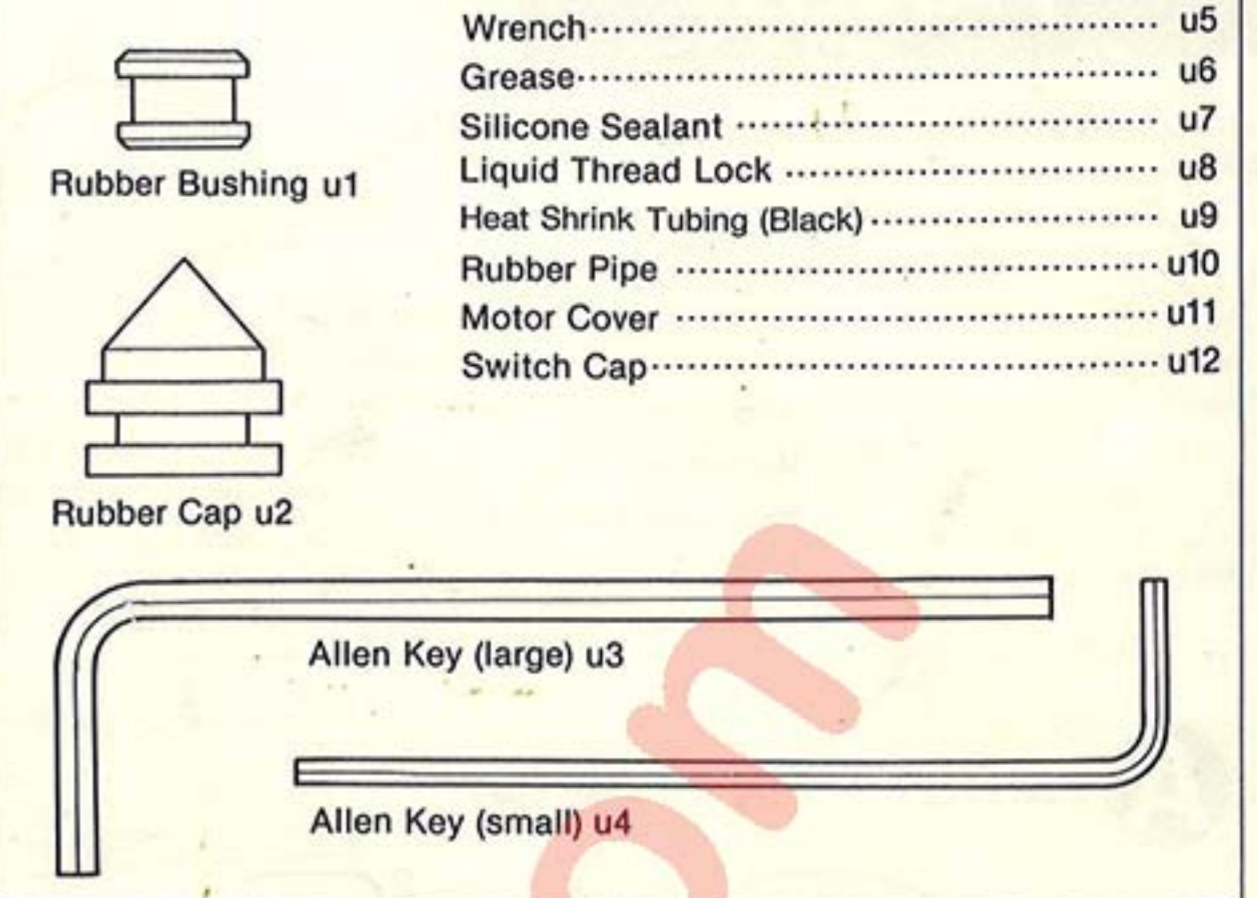

- Wrench ..... u5
- Grease ..... u6
- Silicone Sealant ..... u7
- Liquid Thread Lock ..... u8
- Heat Shrink Tubing (Black) ..... u9
- Rubber Pipe ..... u10
- Motor Cover ..... u11
- Switch Cap ..... u12

«Screw Bag A»

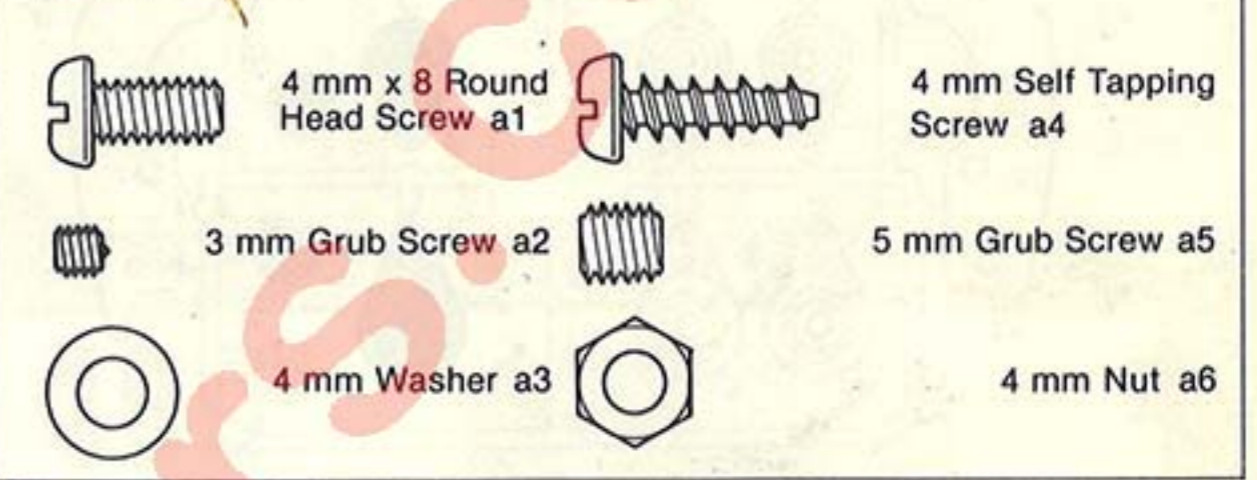

«Screw Bag B»

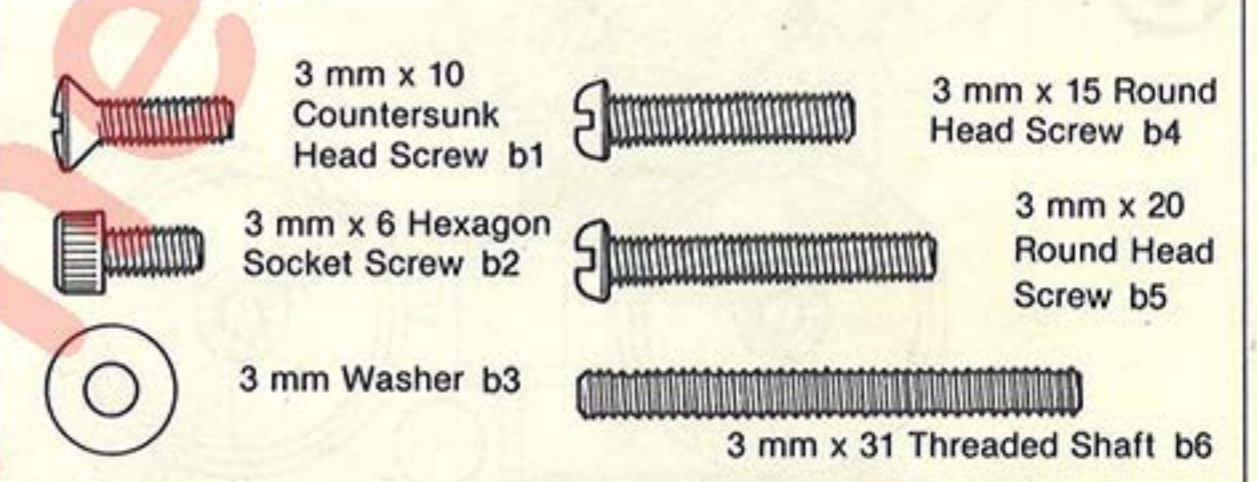

«Screw Bag C»

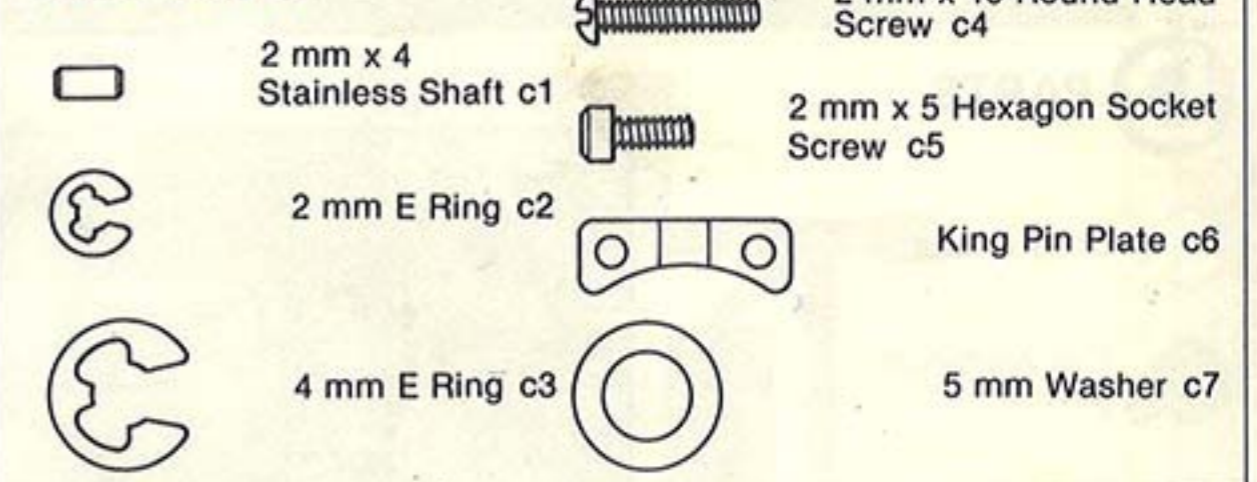

«Screw Bag D»

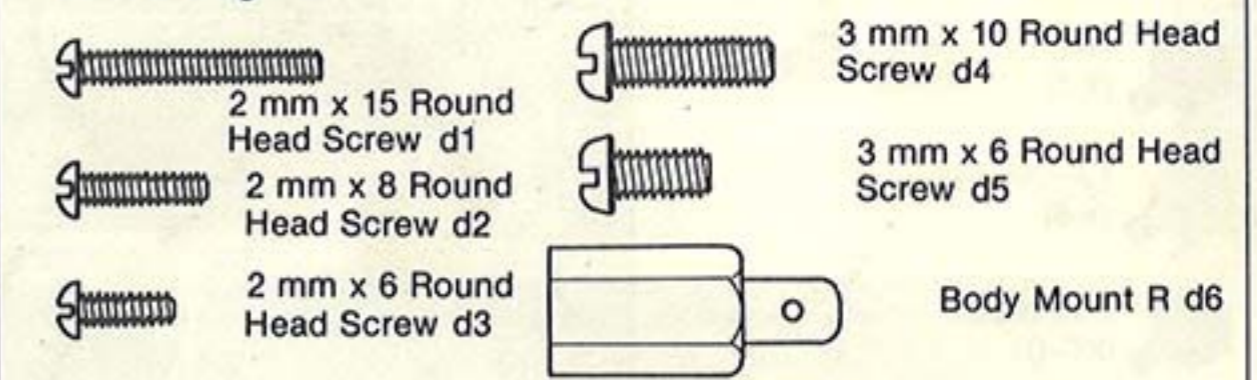

«Screw Bag E»

